



ME371, MT371

Single- and Three-Phase
Electronic Meters with Built-in
DLC Communication Channel

ME372, MT372

Single- and Three-phase
Electronic Meters with Built-in
GSM/GPRS Modem or RS485
Communication Interface



Technical Description

EAD 020.611.325

Version 2.00, 29.05.2008

Content:

Revision history	3
Mx37y – Single- and Three-phase electronic meters	4
1. Energy measurement and registration	6
1.1. Multi-tariff registration.....	6
1.2. Power measurement.....	6
1.3. Load-profile.....	6
1.4. Supplied energy or power limitation.....	7
1.5. Code red.....	7
1.6. Prepaid functionality.....	7
2. Meter appearance (ME37y)	9
2.1. Meter case (ME37y).....	9
2.2. Overall and fixing dimensions (ME37y).....	10
2.3. Meter configuration (ME37y).....	10
2.4. Metering system (ME37y).....	10
3. Meter appearance (MT37y)	11
3.1. MT371.....	11
3.2. MT372.....	11
3.3. Meter case (MT37y).....	11
3.4. Overall and fixing dimensions (MT371).....	14
3.5. Overall and fixing dimensions (MT372).....	15
3.6. Meter configuration (MT37y).....	15
3.7. Metering system (MT37y).....	16
4. Meter configuration	16
4.1. Power supply unit.....	16
4.2. Microcontroller with FRAM.....	16
4.2.1. Load-profile recorder.....	16
4.2.2. Log-book.....	17
4.2.3. Keeping of billing results.....	17
4.3. Real-time clock (RTC).....	17
4.3.1. Time-of-use registration.....	17
4.3.2. Maximum demand.....	17
4.4. Liquid Crystal Display – LCD.....	18
4.4.1. Data display.....	18
4.4.2. Signal flags.....	18
4.5. LED.....	19
4.6. Push-buttons.....	19
4.6.1. RESET and SCROLL push-button.....	19
4.6.2. Manual meter billing reset.....	22
4.7. Communication channels.....	22
4.7.1. Optical port – IR communication interface.....	23
4.7.2. DLC modem (Mx371).....	23
4.7.3. Integrated GSM/GPRS communication interface with antenna (option) (Mx372).....	23
4.7.4. RS485 communication interface (option) (Mx372).....	23

4.7.5. M-Bus communication interface (option).....	23
4.7.6. Readout via built-in communication interfaces.....	23
4.8. AMR readout.....	24
4.9. Inputs and outputs (ME37y).....	25
4.9.1. Alarm inputs.....	25
4.9.2. Load control output.....	25
4.10. Inputs and outputs (MT37y).....	25
4.10.1. Inputs.....	25
4.10.2. Outputs.....	25
5. Additional meter functions	26
5.1. On request reading of E-meter.....	26
5.2. Billing registers reading of E-meter.....	26
5.3. Scheduled reading of E-meter.....	26
5.4. Historic reading of E-meter.....	26
5.5. On request reading of G-meter.....	26
5.6. Billing registers reading of G-meter.....	26
5.7. Scheduled reading of G-meter.....	26
5.8. Historic reading of G-meter.....	27
5.9. Device status.....	27
5.10. Tariff structure configuration of E-meter.....	27
5.11. Remote customer connection/disconnection.....	27
5.12. Load-profile reading of E-meter.....	27
5.13. Load-profile reading of G-meter.....	27
5.14. Load-profile configuration of E-meter.....	27
5.15. Load-profile configuration of G-meter.....	28
5.16. Power quality.....	28
5.17. Power failure registration.....	28
5.18. Alarms.....	28
5.19. Commission E-meter.....	29
5.20. Security.....	29
6. Data protection	29
7. Meter connection procedure	29
7.1. Connection procedure of GSM/GPRS communication interface.....	30
8. Accessory for meters managing	30
9. Meter maintaining	30
10. Anti-fraud protection	31
10.1. Position of the seals.....	31
10.2. Wire seals.....	31
11. Front plate	32
12. Meter connection	32
12.1. Meter connection of ME37y meters.....	32
12.2. Meter connection of MT37y meters.....	33
13. Technical data	34
14. Type designation	37

Revision history

Version	Date	Comment
1.00	12.10.2007	Initial version
2.00	29.05.2008	Double-cage clamp, Capacity of the load-profile recorder 1 and 2, Billing profiles 1 and 2, Alarm inputs, List of error statuses, List of events in event log, Anti-fraud protection, Front plate, Type designation, standards EN 50470–1 and EN 50470–3

Mx37y – Single- and Three-phase electronic meters

The Mx37y single- and three-phase electronic meters are designed for measuring and registration of active, reactive and apparent energy in single phase or in three-phase four- or three-wire network for direct and indirect connection. Measuring and technical characteristics of meters comply with the IEC 62052-11 and IEC 62053-21 international standards for electronic active energy meters, class 1 or 2 (MID, class B or A) , and reactive energy meters, classes 2 or 3 in compliance with IEC 62053-23 as well as a standard for time switches IEC 62052-21.

Measuring and technical characteristics of the meters also comply with the MID standards: EN 50470–1 (Electricity metering equipment - General requirements, tests and test conditions - Metering equipment: class indexes A, B and C) and EN 50470–3 (Electricity metering equipment - Particular requirements - Static meters for active energy: class indexes A, B and C).

Meters are designed and manufactured in compliance with the standards and ISO 9001 as well as more severe Iskraemeco standards.

The **Mx37y** meters are the third generation of Iskraemeco electronic single- and three-phase meters for a deregulated market of electric power, with the following common functional properties:

- Time-of-use measurement of active energy and maximum demand (in up to 4 tariffs)
- Load-profile registration
- LCD in compliance with the VDEW specification
- Internal real-time clock
- Two push-buttons: Reset and Scroll
- Optical port in compliance with the IEC 62056-21 standard for local meter programming and data downloading
- Built-in interface or a modem for remote meter programming and data downloading
- Impulse output
- M-Bus – multi-utility (option)
- Plug-in switching device (option)
- Prepayment functionality (option)
- Limitation of supplied energy or power (option)
- Code red (option)
- Remote connection and disconnection of energy supply to individual customers (option)

The first generation of Iskraemeco electronic meters for a deregulated market of electric power, i.e. the **Mx42y** meters were provided with RS232 or RS485 interface for remote two-way communication, and utilized IEC 62056-21, mode C communication protocol.

The second generation of Iskraemeco electronic meters for a deregulated market of electric power, i.e. the **Mx351** were provided with an integrated DLC modem for two-way communication via low voltage distributions network - or upon request - RS485 interface instead, for remote two-way communication. It utilized the DLMS communication protocol in compliance with the IEC 62056-51 standard as well as IEC 62056-21, mode C protocol. These meters had the following additional functional properties:

- Indication of incorrect connection,
- Bistable relay for demand control
- Two S0 impulse inputs (option).

The third generation of Iskraemeco electronic single- and three-phase meters for a deregulated market of electric power consists of **Mx37y** meter types: with built-in DLC communication channel (Mx371) or GSM/GPRS modem – or upon request – with RS485 interface instead (Mx372), for remote two-way communication.

The meter utilizes the DLMS communication protocol in compliance with the IEC 62056-46 standard as well as IEC 62056-21, mode C protocol. Further to the **Mx37y** meters functionality they also include:

- Detectors of the meter and the terminal cover opening
- Switching device for remote disconnection / reconnection at the customer premises (option)
- M-Bus for reading other meters (heat, gas, water)



Fig. 1: MT371 meter with Z03 plug-in switching device

Mx37y meters properties:

- **Active energy and demand meter**
 - Accuracy class 1 or 2
- **Reactive energy meter**
 - Accuracy class 2 or 3
- **Apparent energy meter**
- **Modes of energy measurement and registration (*single-phase meters*)**
 - For one-way energy flow direction
 - For two-way energy flow direction
 - For two-way energy flow direction but registered in one (absolute) register
- **Modes of energy measurement and registration (*three-phase meters*)**
 - For one-way energy flow direction, three-phase energy is algebraic sum of energies registered in each of the phases – meters are equipped with an electronic reverse running stop
 - For two-way energy flow direction, three-phase energy is algebraic sum of energies registered in each of the phases
 - For one-way energy flow direction, three-phase energy is sum of absolute values of energies registered in each of the phases
- **Meter connection to network**

The three-phase meter can function as a single-phase or a two-phase meter
- **Meter quality:**
 - Due to high accuracy and long-term stability of metering elements no meter re-calibration over its life is required
 - High meter reliability
 - High immunity to EMC
- **Additional meter functions:**
 - Current measurement in a neutral conductor via the fourth measuring system:
 - Detection of missing/broken neutral conductor
 - Detection of phase and voltage unbalance
 - Measurement and registration of under- and over-voltage
 - Generation of alarms and their transmitting via the DLC modem and low voltage network (“alarm pull” at Mx371 – the concentrator reads Alarm ON status and Alarm OFF status register from the meter) or via GSM/GPRS modem or the RS485 communication interface (“alarm push” at Mx372 – GSM modem constantly reads Alarm ON status and Alarm OFF status register from the meter and, if any alarm is active and enabled, it tries to notify the centre about the alarm)
- **Time-of-use registration (up to 4 tariffs):**
 - Tariffs change-over; internal real-time clock
- **Load-profile recorder:**
 - Two load-profile recorders (i.e. daily and hourly values)
- **Communication channels:**
 - Infrared optical port in compliance with the IEC 62056-21 for local meter programming and data downloading
 - Built-in DLC modem (*Mx371*)
 - GSM/GPRS modem (*Mx372*) or
 - Built-in RS485 comm. interface (*Mx372*)
 - Built-in M-Bus comm. interface (option)
- **LCD:**
 - In compliance with the VDEW specification
- **Data display modes:**
 - Automatic cyclic data display with display time of 10 sec.
 - Manual data display mode (by pressing the Scroll push-button)
- **Indicators:**
 - **on LCD:**
 - Presence of phase voltages L1, L2, L3
 - Phase currents flow direction
 - Actual tariff indication
 - Status of switching device
 - Meter status and alarms
 - 3-state GSM signal level indicator (*Mx372*)
 - **LED1:** Imp / kWh
 - **LED2:** Imp / kVArh
- **Communication protocols:**
 - Optical port: IEC 62056 – 21, mode C or DLMS (in compliance with IEC 62056 – 46)

- DLC modem (*Mx371*): DLMS by IEC 62056-46
- GSM/GPRS modem (*Mx372*); IEC 62056 – 46
- RS485 Interface (*Mx372*); IEC 62056 – 46
- Identification system; IEC 62056 – 61
- COSEM organization of data: IEC 62056-53
- M-Bus: EN 13757-2 and EN 13757-3
- **OBIS data identification code:** IEC 62056-61
- **Auxiliary inputs / outputs:**
 - Output for load control with a 6 A relay
 - Output for load control with an Optomos relay
 - Alarm input (low voltage)
 - M-Bus interface to which up to 4 gas, heat or water meters can be connected (also a switching device ZO340-D1)
 - Two impulse outputs or an output for control of a switching device (ZO320-D1)
- **Automatic configuration of an AMR system:**
 - Meters are registered automatically into an AMR system (Intelligent Network Management)
- **Automatic meter setting into the repeater mode (DLC repeater) :**
 - Each meter can automatically enter into the repeater mode and transmit data in both directions, even with meters with which it can not communicate directly.
 - Data transmission of max. 7 remote meters which temporarily operate in the repeater mode increases efficiency of communication and distance between the meters and a data concentrator.
- **Call-back (*Mx372*):**
 - The meter can perform a call and send a message to the centre:
 - After installation
 - If a pre-defined alarm condition exists (e.g. after Power Down/Up event)
 - If a signal appears on the alarm input
- **Programming:**
 - Programming of the meter as well as Firmware upgrade can be done locally (via an optical port) or remotely (via GSM modem – *Mx372*) in compliance with the predefined security levels.
- **Detection of meter and terminal cover opening**
- **Simple and fast meter installation**
- **Current terminals:**
 - Make good contact with current conductors irrespective of their design and material
 - Do not damage conductors
- **Voltage terminals:**
 - Internal and/or external connection
 - A sliding bridge (for simple separation of a voltage part from a current part)
- **Compact plastic meter case:**
 - Made of high quality self-distinguishing UV stabilized material that can be recycled

- IP54 protection against dust and water penetration (by IEC 60529)

1. Energy measurement and registration

The meter measures and records electric energy:

- **In a single-phase two-wire network (also MT37y)**
- **Three-phase three-wire network (MT37y)**
- **Three-phase four-wire network: (MT37y)**
 - total ($\sum Li$)
 - only positive active energy
 - positive and negative active energy (A+, A-) separately
 - absolute active energy $|A|$
 - only positive reactive energy
 - positive and negative reactive energy (R+,R-) separately
 - apparent energy

Meters are provided with two LEDs on the front plate. They are intended for checking the meter accuracy. Impulse constant depends on the meter version (direct or current transformer meter).

1.1. Multi-tariff registration

The meter enables registration of energy and power. Up to four tariffs (8 tariffs is an option) for power and energy can be registered. Tariff changeover is defined with hour and minute. Minimal resolution between changeovers is one minute.

Different combinations of the tariff program are available:

- Up to 4 tariff rates (8 rates as an option)
- Up to 4 seasons
- Up to 4 day types (8 as an option)
- Up to 8 individual changeovers inside individual daily program
- Up to 32 programmable holidays
- Support to lunar holidays in compliance with the Gregorian calendar.

1.2. Power measurement

Power is measured inside a measuring period. The measuring period is a meter parameter and can be set. Values that can be set are 15, 30 and 60 minutes. After termination of the measuring period, the measured meter value is transferred from current measuring period registers to registers for previous measuring period that can be later used for the formation of billing profile values.

1.3. Load-profile

Two load-profile recorders can be provided with up to 16 channels (values) each. In the first load-profile

(time stamp, status, register-value) approx. 33,000 records (60 minutes, ~ 1400 days) and in the second -one approx. 190 (1 day, ~ 190 days) records can be recorded. The saving period (a recording period) can be set. Available values are 15, 30 and 60 minutes or a daily value.

Data in a load-profile recorder are accompanied with a time stamp and with the meter status in the last saving period as well as with a check sum. The time stamp indicates the end of a registration period. Memory capacity of the load-profile recorder for 15-minute registration period is around 190 days (extended load-profile capacity).

1.4. Supplied energy or power limitation

The limitation or disconnection functionality can be activated in the meter itself or by remote action.

The meter disconnects the network (via a switching device) if a maximum energy limit was exceeded during a predefined period of time. The energy level and the allowed exceeding period are set in the meter.

The meter disconnects the network if a maximum power limit was exceeded during a predefined period of time. The power level and the allowed exceeding period are set in the meter.

The customer can (after correcting the exceeding level) reconnect network manually (by pressing the blue button on the meter for 2-5 sec.).

1.5. Code red

“Code Red” is the situation of possible power shortage e.g. due to limitation cooling capacity of the power generation during hot summers. For such situations, in accordance with certain extent, the function can be activated. A “code red” situation is usually preceded by a “code orange”. A “code red” situation typically lasts for a period of few days.

COSEM Objects
Code Red Group ID,
Code Red Start Date,
Code Red Duration,
Code Red Power Limit,
Code Red Active,
Code Red Remaining Duration,
Code Red Meter Group ID.

During “code red” situations the necessary total power amount is limited by setting the maximum consumption threshold of a large number of individual customers (group) to a lower level. This level may be different for individual meters according to the consumer’s contract. Handling “code red” involves a broadcast to all meters and only pre-programmed meters (members of that particular group) shall respond to this action.

Depending on the customer contract the reduction can vary from 0% to 100%. This Information is a part of the configuration ID. The maximum contractual reduction levels are presented in the Configuration Identifier as Code Red ID.

A broadcast shall indicate the group ID, the date and time of which the reduction becomes effective, and the duration of the reduction.

1.6. Prepaid functionality

Prepaid functionality means that a meter only allows consumption up to a remotely pre-set amount of energy or credit paid in advance. At the moment when no more credit is available, or an amount is exceeded, the meter disconnects the customer from the electric network.

A specified prepaid register counts at a rate equal to the amount of consumed energy. The customer can revalue the prepayment meter remotely (tokenless). The prepaid register is tariff based. If the total amount of prepaid cost for energy is consumed, the meter will limit the level (as a warning) for a certain amount of energy before totally disconnecting. If the prepaid amount limit is reached, the customer will be informed by an acoustic signal.

E-meter can operate in Credit or Prepayment Mode depending on the Energy Mode. In Prepayment Mode Available Credit can be revalued with Transaction.

Prepayment accounting

The implementation of prepayment accounting functions can be separated into credit and charge functions. The credit functions include:

- token credit function,
- emergency credit function.

Two types of charge functions are implemented:

- consumption-based tariff charges,
- time-based auxiliary charges.

Token credit:

Token Credit function deals with managing credit registers according to credit token transfer. When credit transfer is accepted, the values of “Available Credit Register” and “Total Purchase Register” are increased for the amount credit transferred.

Emergency credit:

Emergency credit function is used in situations when “Available Credit Register Value” approaches or goes under zero. For this purpose, three parameter objects are implemented:

- “Emergency Credit Initial Limit” is used once after meter installation for the purpose of enabling the customer to make the first buy (or transferring the first credit from the management centre). It defines the credit value which is available when emergency credit is first selected by the customer.

- “Emergency Credit Limit” defines the credit value which is available after the value of “Available Credit Register” reaches zero and the customer selects the emergency credit.

- “Emergency Credit Threshold” defines the positive value of “Available Credit Register” at which the meter begins to notify the customer that the credit will expire. When the value of “Available Credit Register” falls below the value of “Emergency Credit Threshold”, the meter starts notification.

Emergency credit must always be selected by the customer otherwise the meter disconnects the customer from the grid when “Available Credit Register” reaches zero.

Consumption-based tariff charging:

Consumption-based tariff charging is bound to energy consumption register via “Energy Register Reference” object which contains the COSEM logical name of energy consumption register.

In each accounting period the meter calculates the increment of energy consumption from the previous accounting period. The increment is then multiplied by the appropriate tariff charge rate according to meter tariff definition. The calculated charge advance based on consumption is finally charged from the customer’s credit.

Time-based auxiliary charging:

This charging function is used for charges that are fixed over predefined period of time defined as one month. The accounting period of time-based auxiliary charges is one minute. This means that the meter calculates the minute value of auxiliary charge by dividing the auxiliary charge for one month with the number of minutes per month. The minute values are then charged from the customer’s credit every minute. When the meter is powered down, the auxiliary charge is done after power-up, including charges for the whole period of time when the meter was powered-off.



Fig. 2: MT372 meter with Z03 plug-in switching device

2. Meter appearance (ME37y)

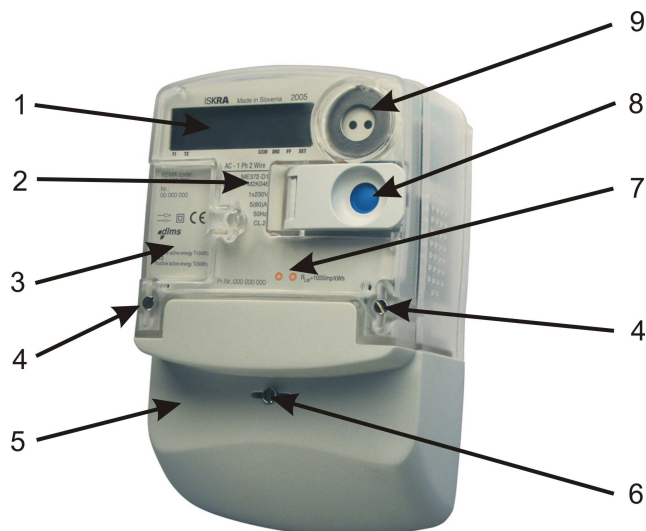

Fig. 3: Meter ME37y constituent parts

ITEM	DESCRIPTION
1	Liquid crystal display (LCD)
2	Meter technical data
3	Legend for data displayed on LCD
4	A meter cover sealing screw
5	A terminal cover
6	A terminal cover sealing screw
7	Impulse LED
8	Scroll (blue) and Reset (orange) push-buttons
9	IR optical interface

Two screws for fixing the meter cover (item 4) are sealed with metrological seals.

The screw for fixing the terminal cover (item 6) and the Reset push-button lid (item 8) are sealed with seals of electric utility.

2.1. Meter case (ME37y)

A compact meter case consists of a meter base with a terminal block and fixing elements for mounting the meter, a meter cover and a terminal cover. The case is made of self-distinguishing UV stabilized polycarbonate which can be recycled. The case ensures double insulation and IP54 (IEC 60529) protection level against dust and water penetration.

The top hanger is provided on the back side of the meter base, under the top edge. On request, an extended top hanger can be mounted on the meter base, which ensures the upper fixing hole height of 155 mm above the line connecting the bottom fixing holes (DIN 43857).

The meter cover is made of transparent polycarbonate. A nickel-plated iron ring in the right top corner is utilized for attaching an optical probe to the optical

port. There is a lid which is fixed to the meter cover with a hinge. The lid covers the Reset push-button and can be sealed in the closed position.

The terminal block contains current terminals, auxiliary terminals and potential links for supplying potential circuits of the meter.

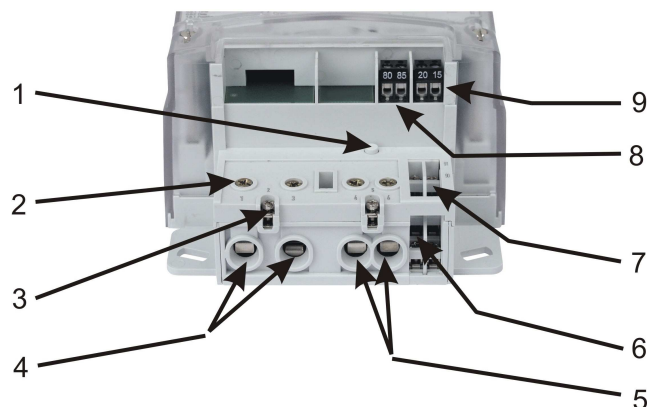

Fig. 4: A terminal block of ME37y meter

ITEM	DESCRIPTION
1	A switch for detection of terminal cover opening
2	A screw for fitting current cables
3	Additional voltage terminals
4	Current terminals
5	Neutral terminals
6	Load control output
7	M-Bus communication interface
8	Second alarm input
9	First alarm input

Current terminals (item 4) are made of galvanized iron sheet. They are universal terminals for all shapes and cross sections of connected conductors up to 35 mm². The terminals ensure the same contact quality with conductors irrespective of whether they are made of copper or aluminum. Only one screw in a current terminal reduces time needed for the meter installation in the field. Due to the indirect pressure on the conductor it is not damaged.

Up to 8 auxiliary terminals can be fitted in the meter. They can be utilized for M-Bus, bistable 6 A relay for load control or alarm inputs. Inputs and outputs are fitted into the meter regarding the customers request at meter ordering.

Voltage terminals (item 3) are built into the meter upon request. They are intended for supplying an add-on unit from the meter terminal block.

Detectors of opening the terminal cover (item 1) and the meter cover are built into the meter.

The terminal cover can be long or short. The meter connection diagram is stuck on the internal side of the terminal cover.

For single phase meters BS terminal block (I_{max} = 100 A) is possible too.

2.2. Overall and fixing dimensions (ME37y)

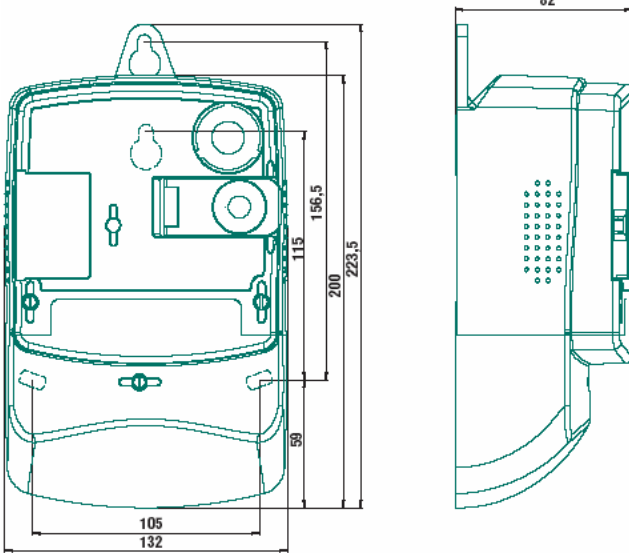

Fig. 5a: Overall and fixing dimensions of a meter fitted with a long terminal cover

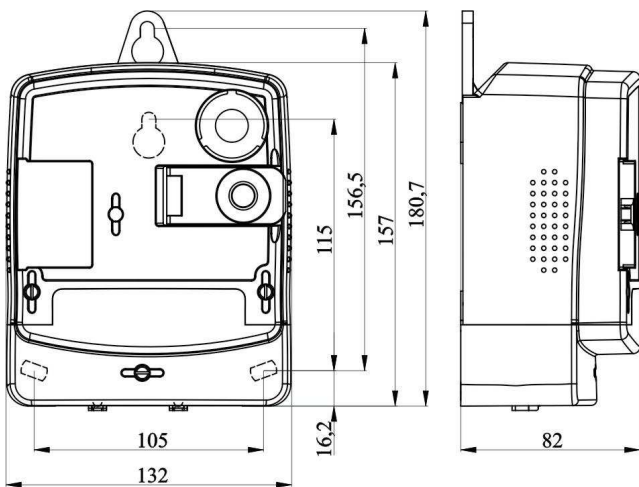
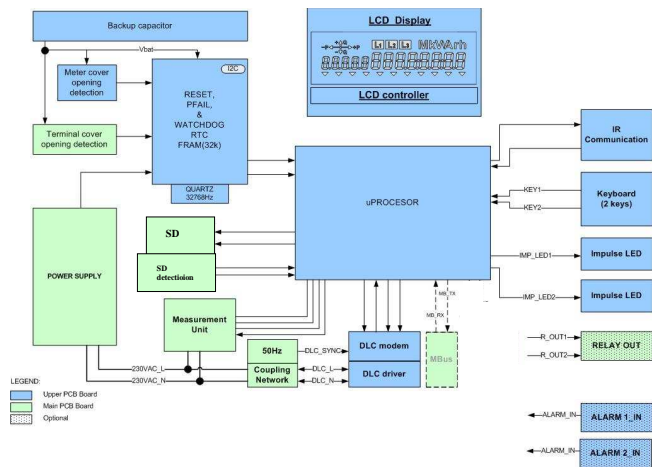

Fig. 5b: Overall and fixing dimensions of a meter fitted with a short terminal cover

2.3. Meter configuration (ME37y)



SD - Switching device

Fig. 6: ME371 meter block diagram

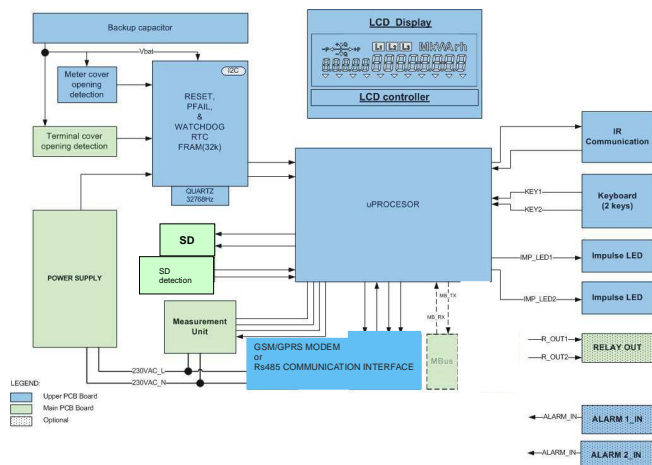

SD - Switching device

Fig. 7: ME372 meter block diagram

2.4. Metering system (ME37y)

Besides precision measurement of active, reactive, apparent energy and demand in a wide metering and temperature range, the metering system enables measurement of phase voltages, currents and supply quality.

One metering element is built in the meter. The current sensor is shunt, while voltage sensor is resistive voltage divider. Signals of currents and voltages are fed to the A/D converters, and then they are digitally multiplied so that instantaneous power is calculated. The instantaneous powers are integrated and summed in a microcontroller, as well as further processed.

3. Meter appearance (MT37y)

3.1. MT371...



Fig. 8: MT371 meter constituent parts

1. Meter base	6. Scroll push-button
2. Meter cover	7. Cover of Reset push-button
3. Fixing screw of meter cover	8. LED
4. LCD	9. Terminal cover
5. Optical port	10. Fixing screw of terminal cover

Two screws for fixing the meter cover (item 3) are sealed with metrological seals.

Two screws for fixing the terminal cover (item 10) and the Reset push-button lid are sealed with seals of electric utility.

3.2. MT372...

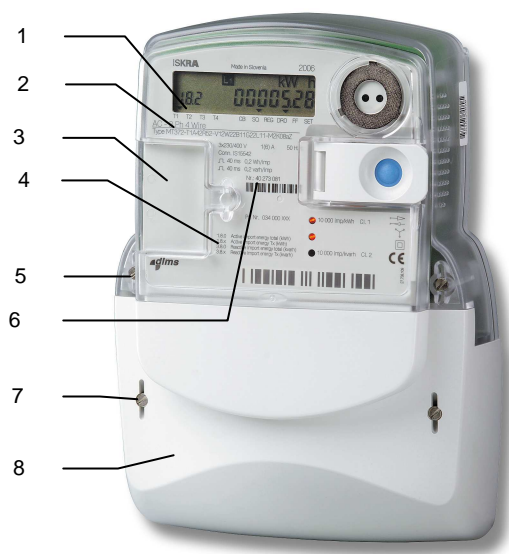

Fig. 9: MT372 meter constituent parts

1. LCD	8. A terminal cover
2. Technical data	9. A project number
3. Coupling circuit	10. A meter BAR code
4. A legend of registers displayed on LCD	11. Impulse LEDs
5. Meter cover sealing screws	12. Meter technical data
6. A meter serial number	13. SCROLL and RESET push-buttons
7. Terminal cover sealing screws	

Two screws for fixing the meter cover (item 5) are sealed with metrological seals.

Two screws for fixing the terminal cover (item 7) and the Reset push-button lid are sealed with seals of electric utility.

3.3. Meter case (MT37y)

A compact meter case consists of a meter base with a terminal block and fixing elements for mounting the meter, a meter cover and a terminal cover. The case is made of self-extinguishing UV stabilized polycarbonate which can be recycled. The case ensures double insulation and IP54 (IEC 60529) protection level against dust and water penetration.

The top hanger is provided on the back side of the meter base, under the top edge. On request, an extended metal top hanger can be mounted on the meter base, which ensures the upper fixing hole height of 230 mm above the line connecting the bottom fixing holes (DIN 43857).

The meter cover is made of transparent polycarbonate. A nickel-plated iron ring in the right top corner is utilized for attaching an optical probe to the optical port. There is a lid which is fixed to the meter cover with a hinge. The lid covers the Reset push-button and can be sealed in the closed position.

A terminal block complies with the DIN 43857 standard. It is made of high quality polycarbonate assuring resistance to high temperatures, voltage-breakdown and mechanical strength.

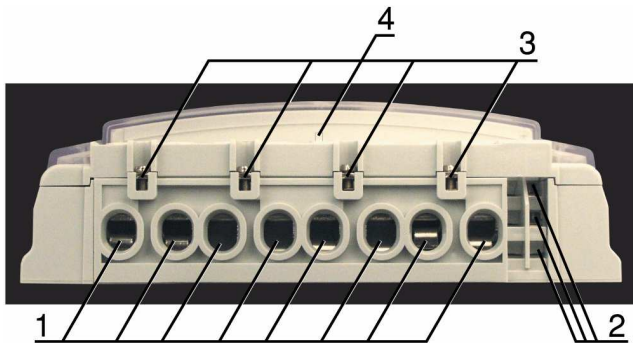

Fig. 10: A terminal block of MT371 meter – bottom view

1. Current terminals	3. Voltage terminals for an add-on unit
2. Auxiliary terminals	4. Detector of opening a terminal cover

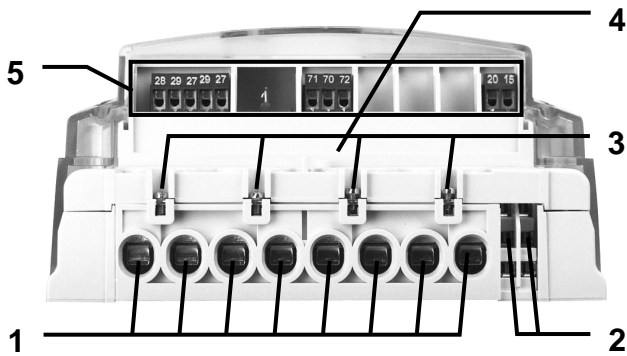

Fig. 11: A terminal block of MT372 meter – bottom view

1. Current terminals	4. Detector of opening a terminal cover
2. Auxiliary terminals	5. Auxiliary terminals – inputs, outputs, SIM card bed, alarm inputs, etc.
3. Additional voltage terminals	

Current terminals (item 1) are made of zinc-plated iron and have only one screw. A universal clamping terminal assures the same quality of the contact irrespective of the shape of the connection conductor (a compact wire, a stranded wire, greater or smaller cross-sections). It also assures faster meter assembly. Available current terminals are:

- Current terminal according to DIN standard for currents up to 85 A with 8.5 mm hole diameter

- Current terminal for currents up to 120 A with 9.5 mm hole diameter
- Current terminal for CT meters for currents up to 6 A with 5.5 mm hole diameter

The meter can be equipped with max. four additional voltage terminals (item 3): 2 (L1), 5 (L2), 8 (L3), 11 (N). They enable simple connection of additional external devices.

Up to 6 auxiliary terminals (item 2) can be fitted in the right side of the current terminals. They can be utilized for M-Bus and optomos relay impulse output or optomos relay control output. Instead of the optomos relay a 6 A bistable relay for load control can be built into the meter. All of them are fitted into the meter regarding the customer request at meter ordering.

Versions:

- two pulse outputs (A+, R+) and relay (6 A) + optomos (100 mA)
- M-Bus and relay (6 A) + optomos (100 mA)

Detectors (switches) of the terminal cover (item 4) and the meter cover opening (on the PCB next to the optical port) are built into the meter.

A sliding voltage bridge is intended for fast and simple separation of meter current and voltage circuit used for calibration or accuracy testing. A special slider is built in each phase of the connection terminal. It can be shifted up and down with a screwdriver.

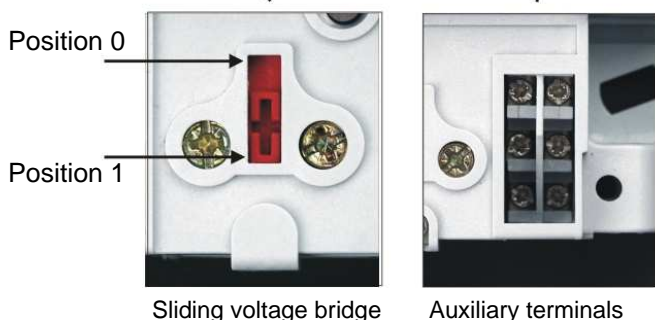
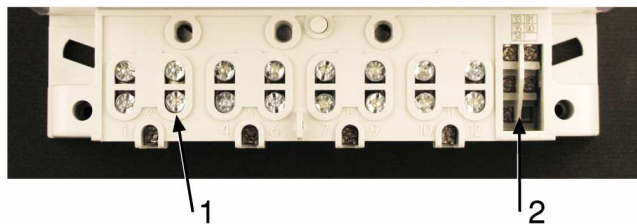

Fig. 12a: A terminal block – sliding voltage bridge and auxiliary terminals

When a voltage bridge is in "0" position, it means that the voltage part is separated from the current part. During the meter testing and calibration the sliding voltage bridges should be in position "0".

When a voltage bridge is in position “1”, the voltage part is not separated from the current part. During the normal meter operation the potential links should be closed (position “1”). Upon request, the potential links can be built under the meter cover.



1	Double cage clamp
2	Auxiliary terminals

Fig. 12b: A terminal block with auxiliary terminals
MT37y : 3x230/400 V, 10(120) A



1	Auxiliary terminals
2	Terminal cover sealing screw

Fig. 12c: A terminal block with auxiliary terminals
MT37y CT : 3x230/400 V, 5(6) A

The terminal cover can be long or short. The meter connection diagram is stuck on the internal side of the terminal cover.

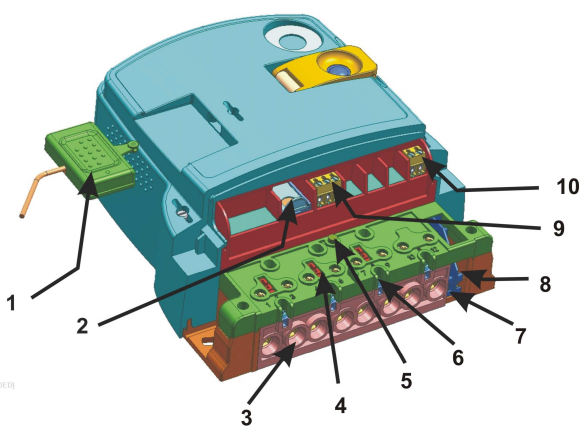

Fig. 13: Details of a terminal block for GSM/GPRS meter

1. Coupling circuit for external antenna	6. Additional voltage terminals
2. SIM card bed	7. Outputs for load control
3. Current terminals	8. M-Bus
4. A sliding voltage bridge	9. Output for switching device control
5. A switch for detection of terminal cover opening	10. Alarm input (low voltage)

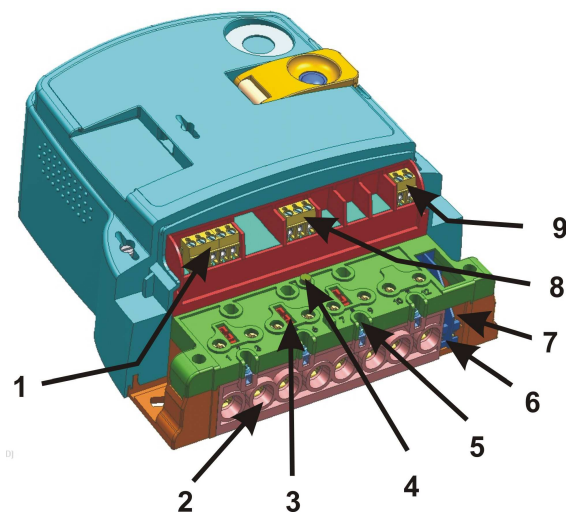

Fig. 14: Details of a terminal block for RS485 meter

1. RS485 comm. interface	6. Outputs for load control
2. Current terminals	7. M-Bus
3. Sliding voltage bridge	8. Output for switching device control
4. A switch for detection of terminal cover opening	9. Alarm input (low voltage)
5. Additional voltage terminals	

3.4. Overall and fixing dimensions (MT371)

Mounting and fixing meter dimensions comply with the DIN 43857 standard.

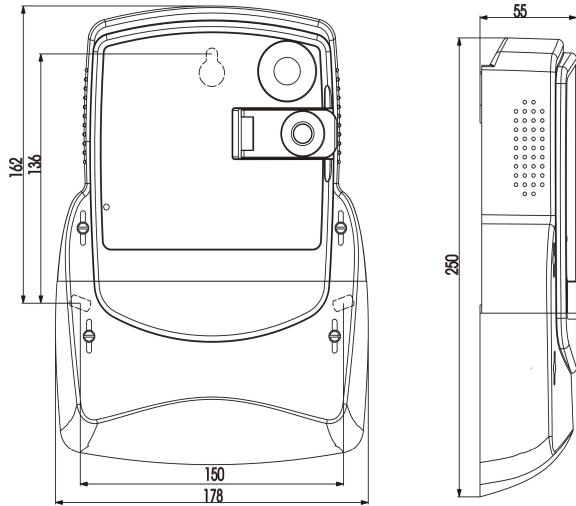

Fig. 15a: Overall and fixing dimensions of an MT371 meter fitted with a long terminal cover

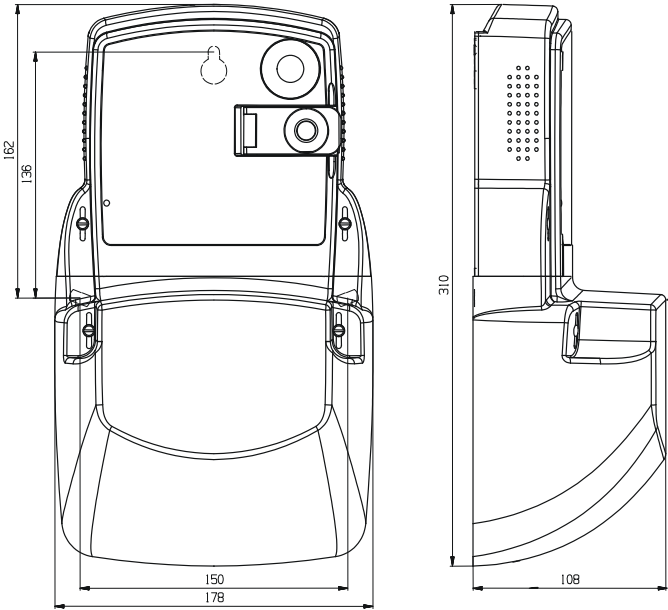

Fig. 16: Overall and fixing dimensions of an MT371 meter fitted with a switching device and a long terminal cover

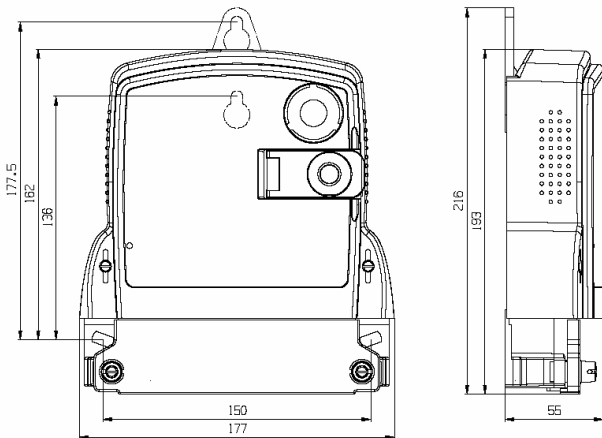

Fig. 15b: Overall and fixing dimensions of an MT371 meter fitted with a short terminal cover

3.5. Overall and fixing dimensions (MT372)

Mounting and fixing meter dimensions comply with the DIN 43857 standard.

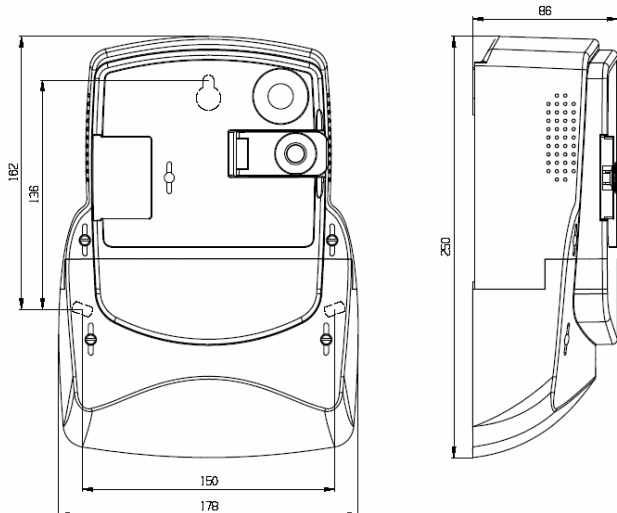

Fig. 17a: Overall and fixing dimensions of an MT372 meter fitted with a long terminal cover

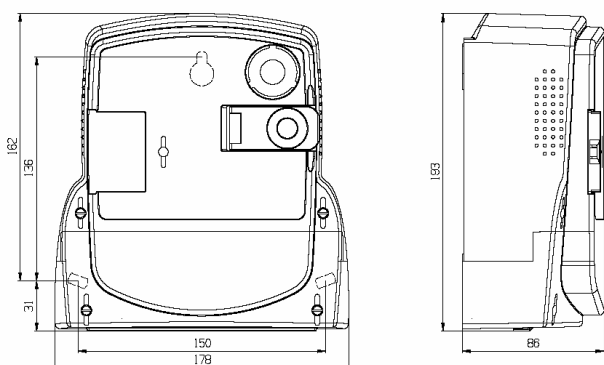

Fig. 17b: Overall and fixing dimensions of an MT372 meter fitted with a short terminal cover

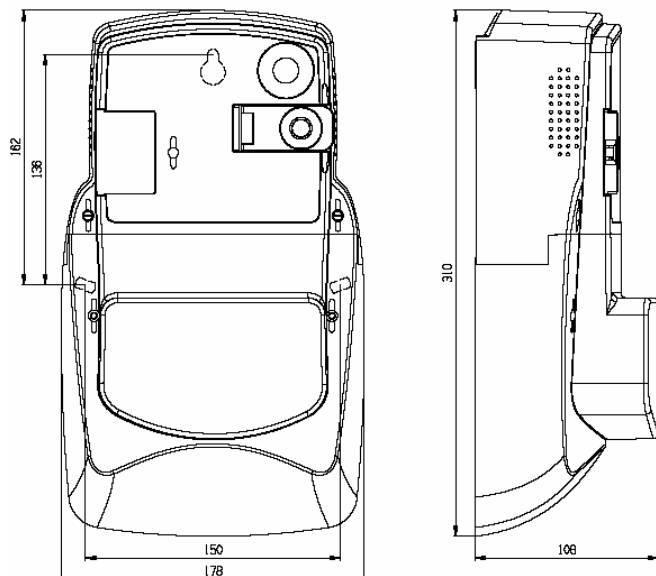

Fig. 18: Overall and fixing dimensions of an MT372 meter fitted with a switching device and a long terminal cover

3.6. Meter configuration (MT37y)

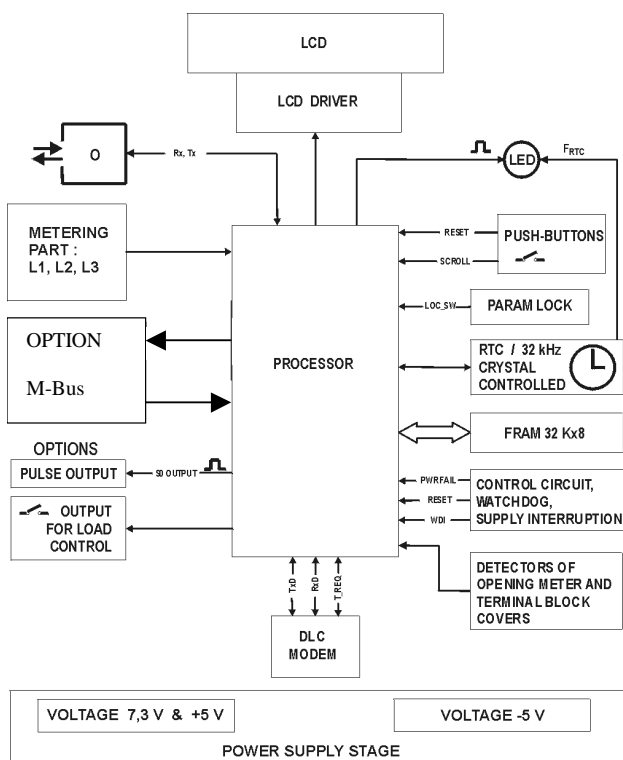

Fig. 19: MT371 meter block diagram

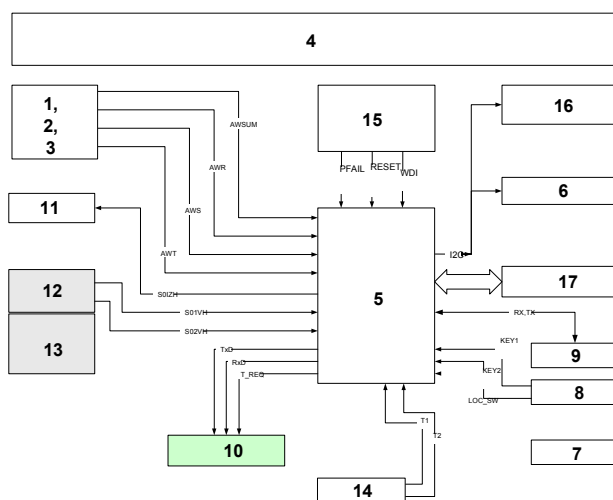

Fig. 20: MT372 meter block diagram

1.2.3. Three metering elements (on request four)	10. GSM/GPRS with a bed for a SIM card or RS485 communication interface
4. A meter power supply unit	11. Inputs; alarm
5. A microcontroller with	12.13. Outputs: relay, switching device control or M-Bus communication interface
17. FRAM memory	
6. Liquid Crystal Display–LCD	14. Tariff inputs
7. Impulse diodes (LED)	15. Control circuits
8. Push buttons (Reset and Scroll)	16. Real time clock - RTC
9. IR optical interface	

3.7. Metering system (MT37y)

Besides precision measurement of active energy and demand in a wide metering and temperature range, the metering system enables measurement of phase voltages and currents.

Three (on request four) metering elements are built in the meter. The current sensor is the Rogowski coil (a current transformer with an air core), while a voltage sensor is a resistive voltage divider. Signals of currents and voltages are fed to the A/D converters, and then they are digitally multiplied so that instantaneous power is calculated. The instantaneous powers are integrated and summed in a microcontroller, as well as further processed.

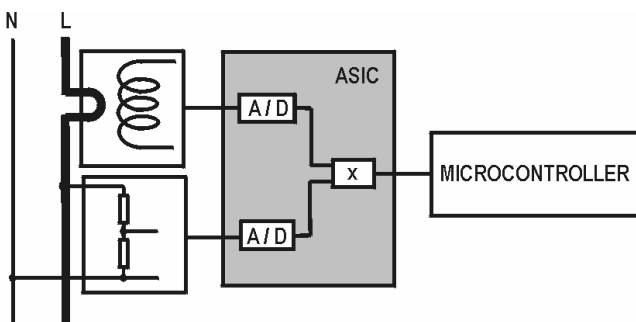

Fig. 21: Metering element

Explosion view of the Rogowski coil is shown in the figure below.

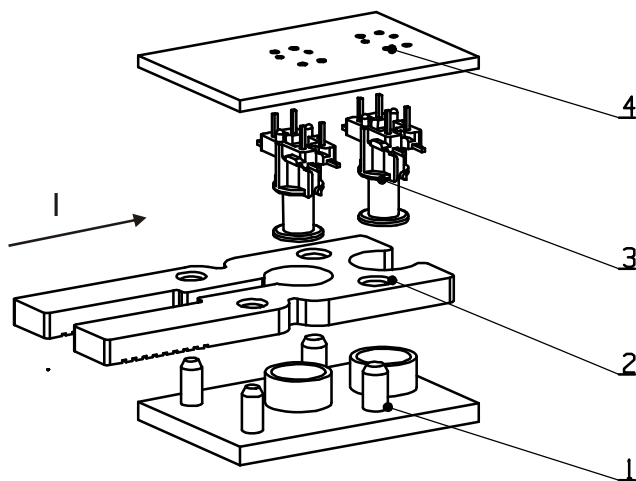

Fig. 22: Explosion view of the Rogowski coil

1. Rogowski coil frame	3. Two Rogowski coils (secondary winding)
2. Meter current loop (primary winding)	4. Printed circuit board

The metering elements ensure excellent metering properties:

1. Wide metering range
2. Negligible influence of disturbances and influence quantities

3. Long-term stability so that meter re-calibration is not required over its life
4. Long meter life and high reliability

4. Meter configuration

Meters consist of:

1. Metering system (items 2.4. and 3.7.)
2. Power supply unit (item 4.1.)
3. Microcontroller with non-volatile FRAM memory (item 4.2.)
4. RTC – Internal real-time clock (Item 4.3.)
5. LCD – Liquid Crystal Display in compliance with VDEW specification (item 4.4.)
6. IR optical port (item 4.7.1.)
7. LEDs (item 4.5.)
8. Two push-buttons (Reset, Scroll) and one push-button under the meter cover (Param) (item 4.6.)
9. DLC modem (Mx371) (item 4.7.2.) or GSM/GPRS (RS485) communication interface (Mx372) (items 4.7.3. and 4.7.4.)
10. M-Bus communication interface (item 4.7.5.)
11. Impulse output or control optomos relay (option)
12. Detectors (switches) of opening a meter and terminal covers
13. M-Bus interface or switching device control output (option)

4.1. Power supply unit

The power supply unit consists of a switcher, which enables a meter to operate accurately in a wide voltage range. It enables a meter to operate accurately even when the meter is supplied from a single phase and voltage in the network is only 80% of the rated voltage.

4.2. Microcontroller with FRAM

The microcontroller acquires signals from the metering element(s), processes them and calculates values of measured energy. The results are stored in energy registers for particular tariffs. It also calculates demands and register maximum demand in billing periods. The microcontroller also generates pulses for the LED and the output pulses, enables two-way communication via the optical port and the DLC modem, and drives the LCD and the control outputs. The microcontroller enables registration of a load-profile and events into a log-book, as well.

4.2.1. Load-profile recorder

A load-profile recorder can be provided with up to two channels. The following registration periods 15, 30 and 60 minutes or a daily value can be set. In each channel up to sixteen objects can be registered of

which two are reserved for time and meter status. The remaining objects are used for registering energy by tariffs:

- Values of energy registers by tariffs depending on the set saving period
- Meter status

Data in a load-profile recorder are accompanied with a time stamp and with the meter status in the last saving period as well as with a check sum. The time stamp indicates the end of a registration period.

Capacity of the load-profile recorder 1:

Capture objects	1	2	3	4	6	8
Number of records	33696	19680	13536	10464	7104	5472

Legend:

Capture objects are without a clock and a status register
A number of records represents profile entries.

Capacity of the load-profile recorder 2:

Capture objects	1	2	3	4	6	8
Number of records	190	140	132	103	81	67

Legend:

Capture objects are without a clock
A number of records represents profile entries.

4.2.2. Log-book

Meters can register up to 128 events and meter status in a log-book which is organized as a FIFO memory. In this way, the last 128 events and meter status are always available. The following events and meter status can be registered:

- Meter fatal error
- Billing reset of the meter
- Time setting of the real-time clock
- Voltage failure
- Voltage re-establishing in the network
- Erased registers of the load-profile recorder
- Erased registers of the log-book
- Phase voltages failure (L1, L2, L3)
- Phase voltages re-establishing (L1, L2, L3)
- Opening of the meter and the terminal covers
- No connection timeout (only DLC meters)
- Prepayment token entry successful
- Prepayment token entry failed
- Prepayment credit expired
- Prepayment emergency credit expired
- Prepayment emergency credit activated

4.2.3. Keeping of billing results

The meter keeps billing results (energy and demand values registered by tariffs) in two billing profile, i.e. a billing profile (billing profile 1) and a capture object profile (billing profile 2).

The billing profile is used for storing billing registers (data banks), and is actuated by billing actions. A billing profile buffer is a place intended for data banks. By default, the first register in a data bank is time mark (0-0:1.0.0).

Billing profiles 1 and 2

Number of registers	2	4	6	8	10
Profile entries	49	36	29	24	20

4.3. Real-time clock (RTC)

A real-time clock involves an internal calendar that assures information on year, month, day, day in a week, hour, minute, second and leap year. The clock accuracy should comply with the IEC 62052-21 standard for time switches.

A super capacitor (super-cap) is used as an auxiliary power supply for surmounting longer power failures (up to 10 days). For a complete charging of the super capacitor the meter should be connected to network voltage for at least 35 minutes. The clock is driven by a crystal with 32.768 kHz frequency.

Option:

For longer failures up to two years long a Lithium battery (3.6 V, 1 Ah, 1/2AA) is applied. A battery is available only for Mx372 RS485 meter.

4.3.1. Time-of-use registration

The meter enables registration of energy and power. Up to four tariffs (8 tariffs is an option) for power and energy can be registered. Tariff changeover is defined with hour and minute. Minimal resolution between changeovers is one minute.

The real-time clock enables complex daily and weekly tariff structures, as well as a couple of seasons in a year.

Different combinations of the tariff program are available:

- Up to 4 tariff rates (8 rates as an option)
- Up to 4 seasons
- Up to 4 day types (8 as an option)
- Up to 8 individual changeovers inside individual daily program
- Up to 32 programmable holidays
- Support to lunar holidays in compliance with the Gregorian calendar.

4.3.2. Maximum demand

The real-time clock generates a demand period. Demand is calculated as an average value over the demand period. The following demand periods can be set in the meter: 15, 30 and 60 minutes. At the end of the demand period, calculated demand value

is transferred from a register for current demand period into a register for previous demand period and is compared with a value in a register of the maximum demand. If a new demand value is larger than the value in the maximum demand register, it is entered into the maximum demand register, otherwise the old maximum demand value is kept. In this way, a maximum demand is registered at the meter billing reset.

4.4. Liquid Crystal Display – LCD

The 7-segment LCD, with additional characters and symbols, complies with the VDEW specifications. Large characters and a wide angle view enable easy data reading.

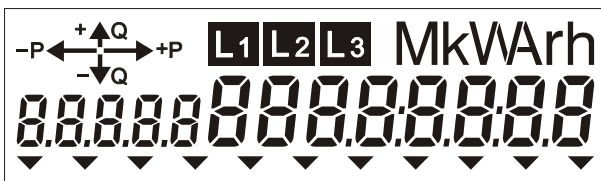

Fig. 23: Liquid Crystal Display – LCD

Data are displayed in the right bottom corner by means of eight 8 mm high alphanumeric characters. The OBIS code (by IEC 62056-61) is employed for data identification. It is displayed in the left bottom corner by means of five 6 mm high alphanumeric characters.

An indicator of energy flow direction is displayed in the left top corner. A physical unit of displayed quantity is shown in the right top corner. The indicator of L1, L2 and L3 phase voltages presence is displayed in the middle of the top row. If certain phase voltage is not present, the indicator of that phase is not displayed.

In the LCD bottom row there are eleven signal flags that indicate current valid tariff, meter status and alarms. Meaning of each signal flag is engraved on the meter name plate below each of the signal flags in use.

4.4.1. Data display

Data defined in Auto scroll sequence and in Manual scroll sequence are displayed on the LCD. Data from Auto scroll sequence are displayed in a circle - each is displayed for 10 sec. On request, longer data display time can be set. At Manual scroll sequence the blue push-button should be pressed for displaying the next piece of data. Data in Manual scroll sequence remains displayed until the blue push-button is pressed again or until time for automatic return into the Auto scroll sequence is not elapsed.

Data that can be displayed are listed in the table below. Which of them will be displayed depends on customer request at meter ordering:

CODE	DATA DESCRIPTION
0.0.0	Meter serial number
C.1.0	Meter manufacturer number
0.9.1	Time
0.9.2	Date
1.8.0	Total imported active energy (A+)
15.8.0	Total absolute active energy A
1.8.1	Imported active energy in the first tariff (T1)
15.8.1	Absolute active energy in the first tariff T1
1.8.2	Imported active energy in the 2-nd tariff (T2)
15.8.2	Absolute active energy in the 2-nd tariff T2
1.8.3	Imported active energy in the third tariff (T3)
15.8.3	Absolute active energy in the third tariff T3
1.8.4	Imported active energy in the fourth tariff (T4)
15.8.4	Absolute active energy in the fourth tariff T4
2.8.0	Total exported active energy (A-)
2.8.1	Exported active energy in the first tariff (T1)
2.8.2	Exported active energy in the 2-nd tariff (T2)
2.8.3	Exported active energy in the third tariff (T3)
2.8.4	Exported active energy in the 4-th tariff (T4)
1.6.1	A+ import. max. demand in the first tariff (T1)
1.6.2	A+ import. max. demand in the 2-nd tariff (T2)
1.6.3	A+ import. max. demand in the 3-rd tariff (T3)
1.6.4	A+ import. max. demand in the 4-th tariff (T4)
2.6.1	A- export. max. demand in the first tariff (T1)
2.6.2	A- export. max. demand in the 2-nd tariff (T2)
2.6.3	A- export. max. demand in the 3-rd tariff (T3)
2.6.4	A- export. max. demand in the 4-th tariff (T4)
3.8.0	Reactive energy import total
3.8.x	Reactive energy import in tariff x
4.8.0	Reactive energy export total
4.8.x	Reactive energy export in tariff x
F.F	Meter fatal error

4.4.2. Signal flags

The signal flags in the display bottom row indicate certain meter status and alarms. The following flags are active at the MT372 meters (depending on the meter type – RS485, GSM/GPRS, M-Bus):

INDICATION	STATUS	MEANING
T1	Lit	The first tariff is active
T2	Lit	The second tariff is active
T3	Lit	The third tariff is active
T4	Lit	The fourth tariff is active
T1, T2, T3, T4	Blinking	The meter is in the program mode. Mode is accessible when seals from the meter cover are removed
BR	Lit	Billing reset is activated. It is lit until expiration of MD period
SD	Lit	Switching device has disconnected a customer (contacts are open)

INDICATION	STATUS	MEANING
SQ	Lit	Indicates signal strength: good covering with a GSM/GPRS signal
	Blinking	Bad covering with the GSM/GPRS signal. An external antenna is recommended
	Not Lit	Very bad or no covering with the GSM/GPRS signal. An external antenna is required
REG	Lit	Indicates that the meter is ready for telecommunication network
DRO	Lit	Meter data downloading or uploading is in progress
	Blinking	Data package is present in the AMR communication network
FF	Lit	Meter fatal error (the meter should be dismantled and sent to examination)
EC	Lit	Emergency credit is activated
	Blinking	When available credit crosses the emergency credit threshold

* If the FF code is displayed, the meter should be dismantled from a place of measurement and sent to an authorized repair shop or to the manufacturer for examination.

4.5. LED

The meter is provided with two LEDs on the front plate. One indicates active energy flow, the other reactive energy flow. They are intended for checking the meter accuracy. Impulse constant depends on the meter version.

In normal meter operation mode, the LED emits pulses with frequency that is proportional to the measured power and is intended for the meter calibration and testing. The LED is turned on and glows steadily if load is lower than the meter starting current.

4.6. Push-buttons

Two push-buttons are built in the cover of three-phase meters:

- **RESET** – orange with a sealing option,
- **SCROLL** – blue.

Two push-buttons enable:

- Switching over among the meter operation modes
- Browsing through measuring results and adjustments

As to the duration, we distinguish three different pressings on the push-button:

- **short pressing** – pressing time shorter than 2 s,
- **long pressing** – pressing time between 2 s and 5 s,
- **prolonged pressing** – pressing time longer than 5 s.



Fig. 24: Push-buttons

Besides the above described push-buttons, the meters are provided with the third one, which is built in the PCB under the meter cover – a Param lock switch. When unlocked, it enables to enter the meter programming in a laboratory, and at the same time it is used as a hardware-lock against tamper attempt.

4.6.1. RESET and SCROLL push-button

RESET push-button

Push-button functions are:

- Switching to the meter test operation mode
- Billing reset

The push-button can be locked by a seal.

DURATION OF PRESSING ON THE PUSH-BUTTON TP [S]	COMMAND
$0.2 < T_p < 2$	BILLING RESET
$2 < T_p < 5$	MENU
$5 > T_p$	RESET

Billing reset by pressing the RESET push-button is active only in AUTOSCROLL mode.

SCROLL push-button

Push-button functions are:

- LCD display test

The LCD should be tested in order to check if all its segments are in order.

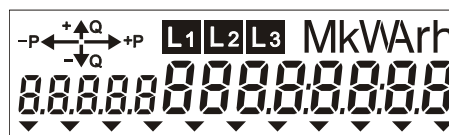

- Displayed data list
- Switching to the meter test operation mode

DURATION OF PRESSING ON THE PUSH-BUTTON TP [S]	COMMAND
$0.2 < T_p < 2$	SCROLL
$2 < T_p < 5$	ENTER
$5 < T_p$	ESC

sequences with Param lock switch off. The push-buttons pressing are tracked by messages on a display (Fig. 25: Normal reset type)

Menu navigation

After power up, a meter is in autoscroll mode. Predefined menu is available by appropriate push-button pressing (Fig. 26 and 27)

Normal type

Normal type means normal common data display of internal objects counted in object 0-0:21.0.1. After power up, display is in normal type mode and shows values counted in object 0-0:21.0.1, every 12s consecutive.

Reduce type

Reduce type means data display of internal objects counted in object 0-0:21.0.2. We can enter this mode by appropriate pressing the SCROLL push-button.

Meter reset

The Reset (orange) and Scroll (blue) push-buttons are used for resetting the meter by pressing appropriate push-buttons, following predefined time

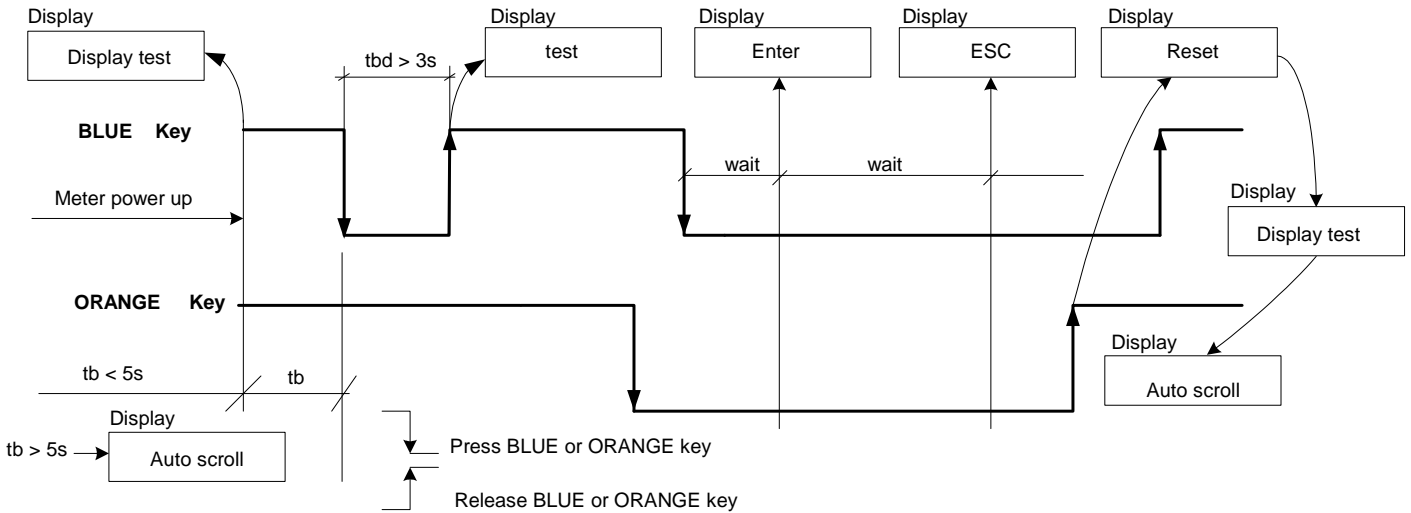

Fig. 25: Normal reset type

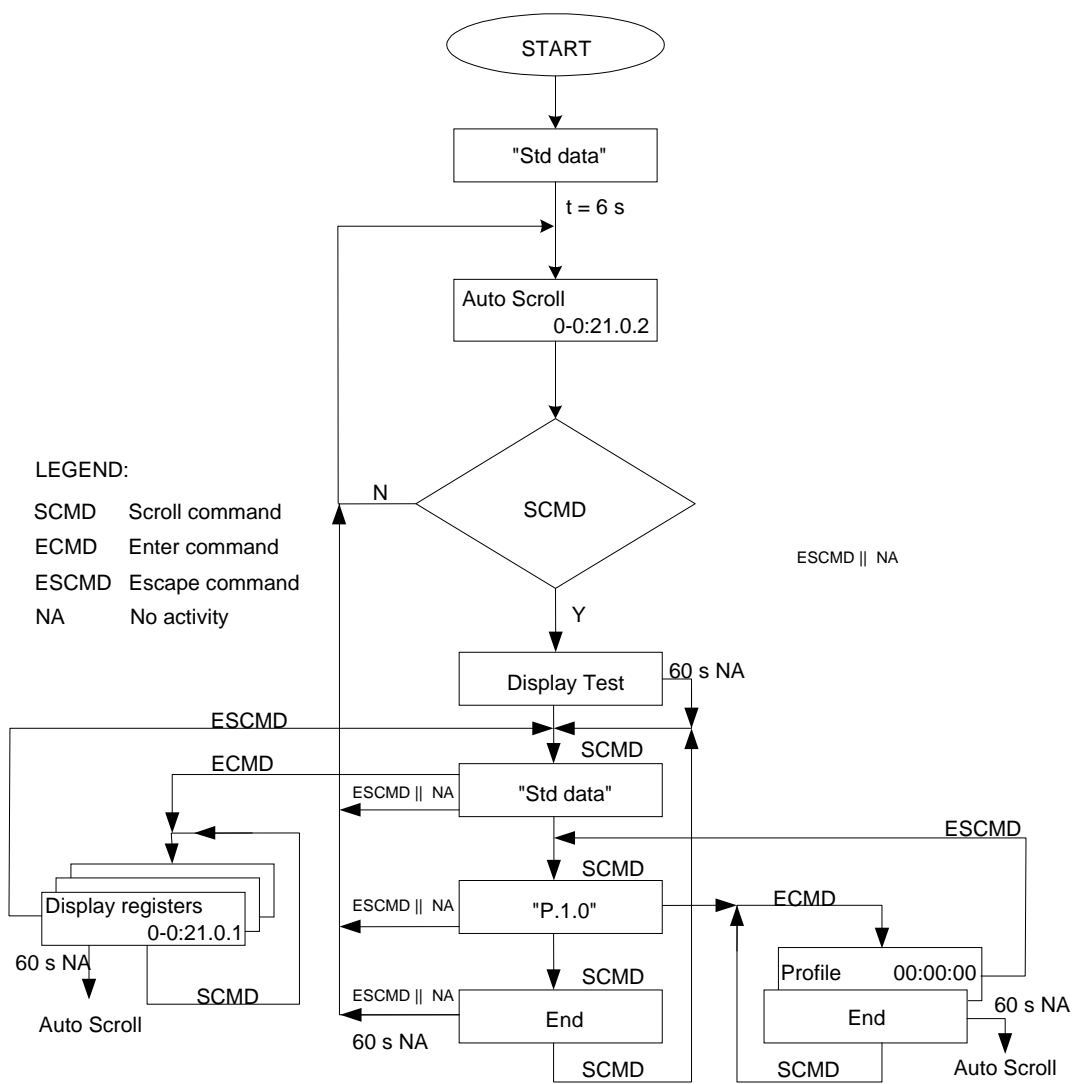

Fig. 26: Reduce menu navigation

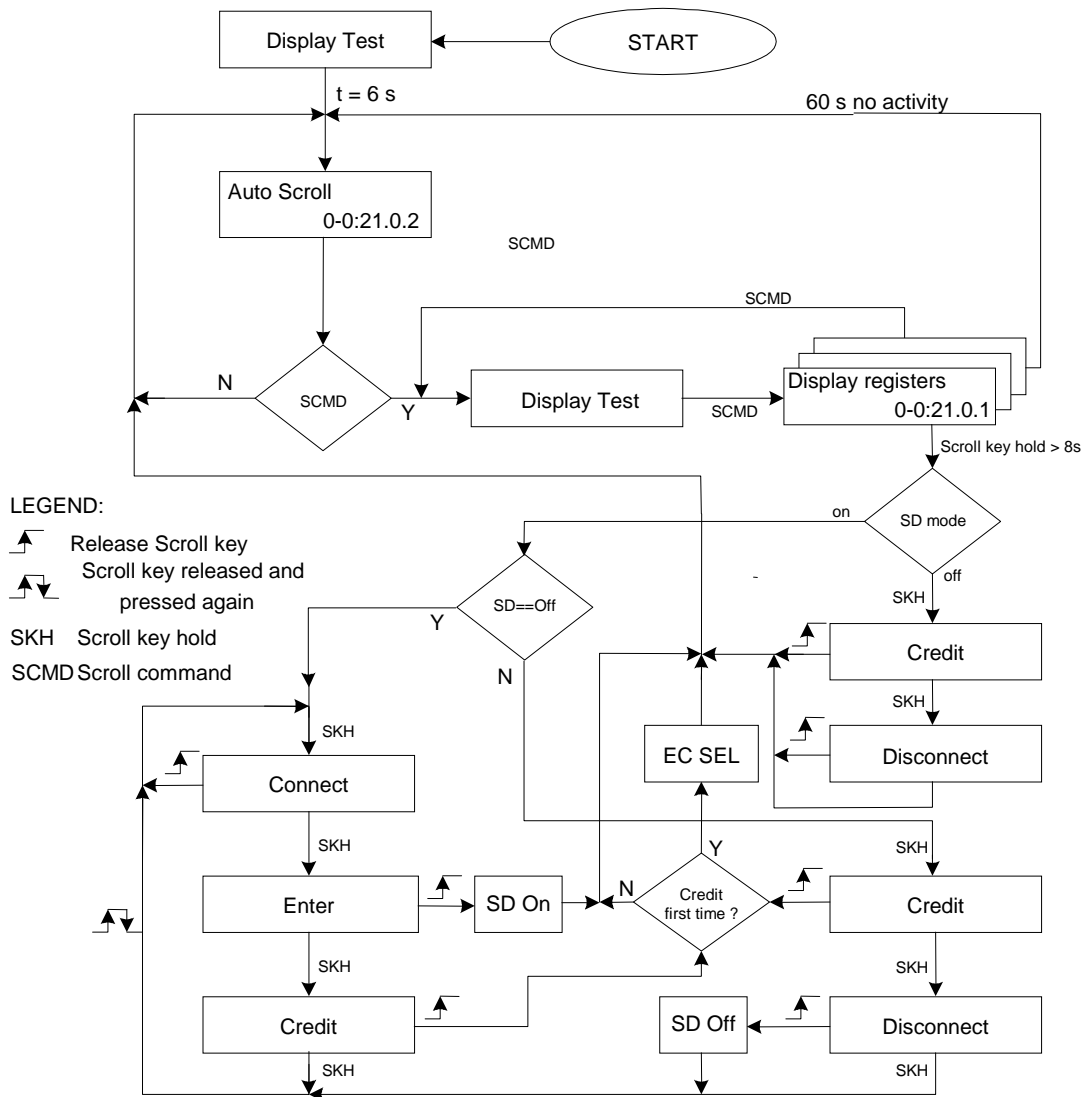

Fig. 27: Menu navigation

4.6.2. Manual meter billing reset

In order to perform manual billing reset of the meter, so that the meter is made ready for a new billing period, the seal of the Reset (orange) push-button lid should be broken. The Reset push-button should be pressed when the meter is in the Autoscroll mode. The billing reset is not performed immediately – the microcontroller waits until the current demand period is completed. As long as the microcontroller waits to execute the meter billing reset, the BR signal flag is displayed.

In order to prevent tamper attempts of the Reset push-button after meter billing reset, the orange push-button is disabled for one demand period. If the Reset push-button is pressed again in a time period shorter than the demand period, the second meter reset command will not be carried out.

After pressing the Reset push-button, its lid should be closed and sealed again.

Upon request, the function of manual meter billing reset can be disabled by software.

4.7. Communication channels

The Mx37y meters are equipped with the following communication channels:

- Optical port – IR communication interface
- DLC modem (Mx371)
- GSM/GPRS communication interface with antenna – option (Mx372)
- RS 485 comm. interface – option (Mx372)
- M-Bus communication interface – option

4.7.1. Optical port – IR communication interface



Fig. 28: Meter readout via an IR optical interface

The optical port complies with the IEC 62056-21 and is used for local meter programming and data downloading. It is located in the right top corner of the meter. The communication protocol complies with IEC 62056-21, mode C or DLMS-HDLC IEC 62056-46. The communication is serial asynchronous with data transmission rate from 300 bit/sec to 19,200 bit/sec. If data transmission rate of the used optical probe is lower than 19,200 bit/sec, the maximum permissible data transmission rate is equal to that value. If higher data transmission rate is set, communication via optical port will not be possible.

4.7.2. DLC modem (Mx371)

A DLC modem for remote two-way communication is built into the meter. The DLC modem is connected to the low voltage network internally via L3 phase. For successful communication with the meter it is therefore necessary that L3 phase and neutral conductors are connected to the meter. If the MT371 meter is installed in a single-phase network, the phase conductor should be connected to its L3 phase terminal.

The DLC modem enables two-way communication with a data concentrator built at the low voltage side of a substation via low voltage network. Data transmission rate via low voltage network can be up to 1,200 bit/sec. Data transmission rate between the microcontroller and the DLC modem is serial asynchronous with data transmission rate of 4,800 bit/sec.

4.7.3. Integrated GSM/GPRS communication interface with antenna (option) (Mx372)

It enables data transmission via a communication interface towards the centre for management and billing or a data concentrator. Data transmission rate via network is 9600 baud/s, while actual data transmission rate depends on momentary conditions in network.

A GSM antenna is built in the meter. It enables operation in three frequency ranges:

- 900 MHz
- 915 MHz
- 1800 MHz

If a built-in antenna does not meet the needs of covering the signal, an external antenna can be mounted. Coupling circuit is placed on the meter cover and enables a simple mounting of a coupling module.

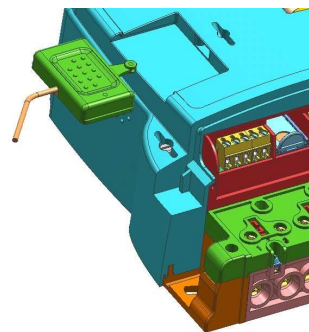

Fig. 29: Coupling circuit

4.7.4. RS485 communication interface (option) (Mx372)

A built-in communication interface enables setting of meter parameters and a local readout of measuring results. The protocol for data transfer is IEC 62056 – 46.

4.7.5. M-Bus communication interface (option)

There is M-Bus communication interface integrated in Mx37y meters according to EN 13757-2 and EN 13757-3 micro-master specifications. It enables connection of 4 slave devices (water, gas or/and heat meters) and max. length of wiring 50 m. Auto-install procedure is implemented.

4.7.6. Readout via built-in communication interfaces

Built-in communication interfaces enable:

- Reading of meter registers
- Reading of load-profile recorder
- Reading of meter parameters
- Changing of meter parameters

Communication state is shown on a display, i.e.:

DLC modem: during communication, a flag above a DRO mark is blinking

RS485 and IR interface: during communication, a flag above a DRO mark is blinking

GSM/GPRS interface: at successful communication, several flags are displayed. The flag above the SQ mark indicates signal strength, the flag above the REG mark – if present - indicates that the meter is ready for telecommunication network, and the flag above the DRO mark indicates that communication is going on.

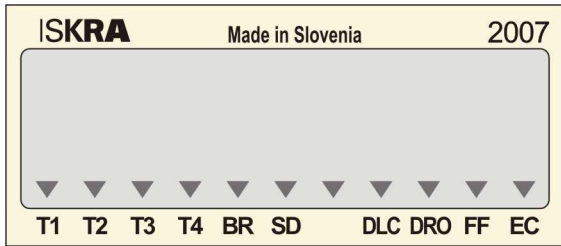

Fig. 30: Display legend, Mx371 (DLC)

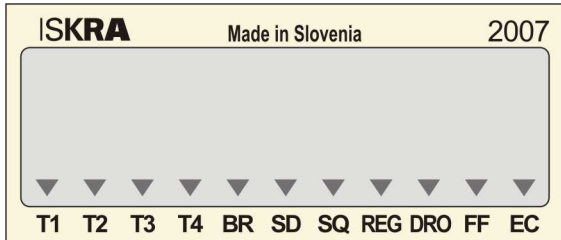

Fig. 31: Display legend, Mx372 (GSM/GPRS, RS485)

4.8. AMR readout

To establish the system for automatic meter readout (AMR) two basic components are required:

- A meter: Mx371 (Server),
- A concentrator P2LPC (Client).

Communication between the meter and the concentrator is performed via a DLC modem that is built in the meter and the concentrator.

For correct recognition of the meter by the concentrator, some identification numbers that are stated in the table below should be written.

CODE	DESCRIPTION
1-0:0.0.0	Device number
0-0:96.1.0	Device factory number
0-0:128.0.0	DLC MAC meter number
0-0:128.0.3	Device unique ID

Communication is performed as follows:

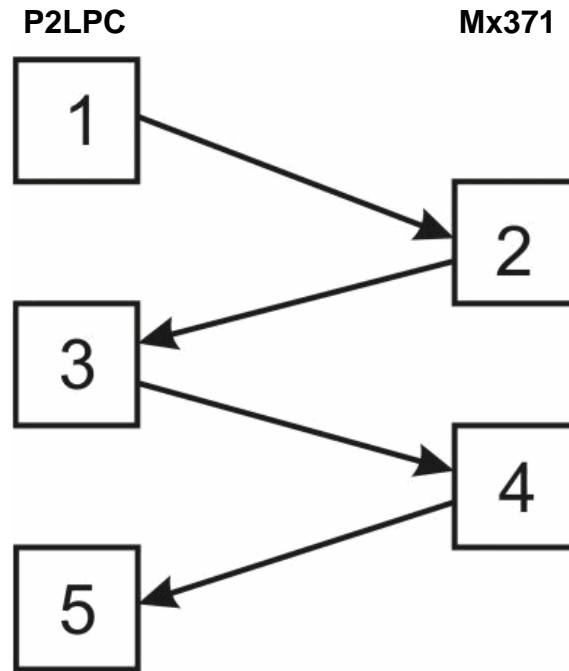

1. Find_request[clientDLC,serverDLCnew]
2. Find_respond[serverDLCnew,clientDLC,DUID]
3. Install_request[clientDLC,serverDLC,DUID]
4. Install_respond[serverDLC,clientDLC,DUID]
5. Install_confirm[clientDLC,serverDLC,DUID]

A request for searching new installed meters in a network has a DLC number P2LPC (0-0:128.0.0) which is allocated within the range from 3072 to 4090.

The meter answers the request for searching with a certificate which has a DLC number P2LPC (0-0:128.0.0) and its own DUID number (0-0:128.0.3).

Before installation, P2LPC checks if the sent DUID number (0-0:128.0.3) already exists. If it does, a new DLC number is allocated (0-0:128.0.0) to just obtained DUID number (0-0:128.0.3).

When connection between P2LPC and the meter is established, the meter accessibility should be checked periodically (“Fork”) in order to find out if the meter is accessible for readout procedure. Up to ten successive searchings of the meter can be defined.

If the meter does not respond even after the last successive searching, “deinstallation” procedure is started. When it is finished, a DLC number is released (0-0:128.0.0) on the concentrator and is set at the end of the table of available DLC numbers (0-0:128.0.0) of the concentrator.

4.9. Inputs and outputs (ME37y)

Meters can be equipped with up to ten auxiliary terminals. The following inputs and outputs are possible:

- Two Alarm inputs (option)
- Output for load control by a bistable 6 A relay
- M-Bus communication interface

4.9.1. Alarm inputs

Up to two inputs for detecting auxiliary alarm are available. They are open collector type.

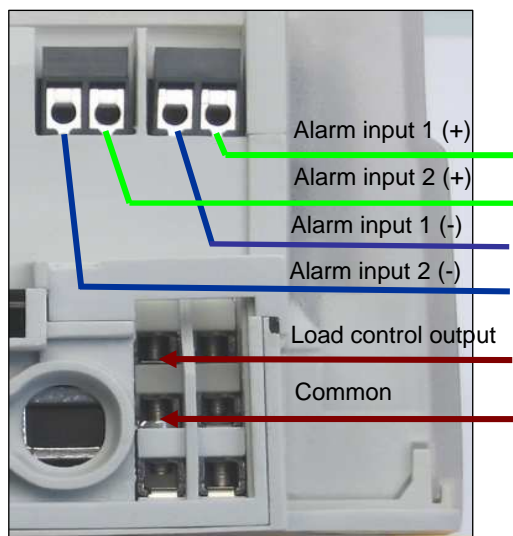

Fig. 32: Position of alarm inputs and outputs on ME37y meters – bottom view

4.9.2. Load control output

The load control output is a bistable relay. The relay is capable of switching 250 V, 6 A. Depending on a customer request the relay can be controlled by time-schedule set in the meter (for ON/OFF switching of appliances by a time-schedule), by calculating trend of maximum demand (load limiter function), or by remote command (together with an integrated switching device – function of remote disconnecting /reconnecting on customer premises).

4.10. Inputs and outputs (MT37y)

MT371: Auxiliary terminals for meter inputs and outputs are on the right side of the meter terminal block compartment. Meters can be provided with up to six auxiliary terminals. The following inputs and outputs are possible:

- Impulse output – Optomos relay (option)
- Output for load control with a bistable 6 A relay (alternatively, instead of the impulse output)
- M-Bus communication interface (option)
- Switching device control output (option)

MT372: Input-output connection terminals are placed on the right side of the meter terminal block as well as on the upper additional plate.

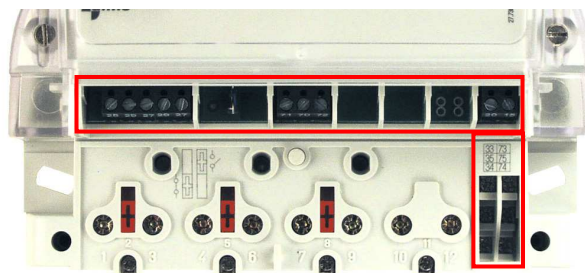

Fig. 33: Position of inputs and outputs on MT372 meter – front view

Eleven auxiliary connection terminals are used for

- Output for load control performed by a relay
- Output for load control performed by an optomos
- Output for switching device control. On request, outputs can be used as impulse outputs
- Two alarm inputs (low voltage)
- A bed for a SIM card
- M-Bus communication interface (option)

4.10.1. Inputs

The meter is equipped with two alarm inputs that occupy four connection terminals.

Input for the alarm is a passive type and is controlled with voltage on terminals. Control voltage is from 3 V to 24 V AC/DC (230 V control voltage is available on request).

4.10.2. Outputs

The meter is equipped with three outputs occupying six connection terminals.

There are two outputs for load control. One with a relay that is capable of switching 250 V, 6 A, and another one that is performed with an Optomos element and is capable of switching 250 V, 100 mA. It is possible to control each control output separately, depending on the written tariff program or on received command.

On request, meters can be equipped with an external plug-in unit – a switching device. The switching device is equipped with a terminal cover, and can be sealed.

Assembly is simple since one part is inserted into the meter terminal block, and another part is extension of the terminal block. The meter with the switching device as a whole complies with the DIN 43857 standard or the stated fixing dimensions.

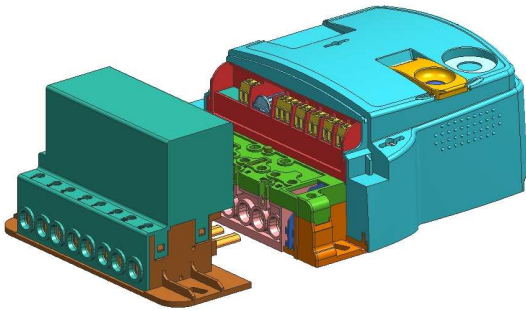

Fig. 34: Assembly of Z03 plug-in switching device



Fig. 35: MT372 meter with Z03 plug-in switching device

- Remote setting of an energy / power consumption thresholds of individual customers.
- Remote setting of an energy / power consumption threshold groups of customers (e.g. “Code Red”), by a broadcast with group identifier.
- Retrieving device status.
- Remote connecting and disconnecting the energy supply of individual customers.

5.1. On request reading of E-meter

The “On request reading of E-meter” is a service for meter reading requested by a call centre agent during a customer call. The meter reading represents the current reading of the meter display.

5.2. Billing registers reading of E-meter

Meter read in order to prepare energy or other object instances measurement values. Values are the basis for preparing an invoice paper. In this case the meter reading is stored at the end of a billing interval and captured at a specific defined moment. Meter reading is time stamped at the end of a billing interval. A billing interval is configured in advance and can be changed remotely.

5.3. Scheduled reading of E-meter

The meter reading is scheduled later e.g. at the moment of a tariff changeover, or at an energy supplier switch.

5.4. Historic reading of E-meter

Meter reading for analysis, for reference, for disputes on invoices and to enable recovery of lost data, both billing and scheduled readings.

5.5. On request reading of G-meter

The “On request reading of G-meter” is a service of electricity meter. Read is invoked by a call centre agent during a customer call. The meter read represents the current reading of the meters. External meters are connected to the E-meter with the M-Bus.

5.6. Billing registers reading of G-meter

The “Billing registers reading of G-meter” is meter reading in order to prepare a monthly, quarterly or yearly invoice. In this case, the meter reading is stored at the end of a billing interval and captured at a specific defined moment. Gas meter reading is time stamped at the end of a billing interval. A billing interval is configured in advance and can be changed remotely.

5.7. Scheduled reading of G-meter

The gas meter reading is scheduled later e.g. at the moment of a tariff changeover, or at an energy supplier switch.

5. Additional meter functions

- Collection of energy consumption information in subsequent billing periods of individual customers and/or a (larger) number of customers.
- On request, reading of energy consumption information.
- Collection of supply quality information (e.g. sags, voltage measurements) of individual customers.
- Collection of information saved in profiles of individual customers and/or a (larger) number of customers.
- Collection of power failure duration information of individual customers and/or a (larger) number of customers.
- Prepaid functionality.
- Setting and retrieving different tariff structures (i.e. different combinations of tiers and timeslots) including the consumption thresholds in the meter of individual customers and/or a (larger) number of customers.

5.8. Historic reading of G-meter

Meter reading for analysis, for reference, for disputes on invoices and to enable recovery of lost data, both billing and scheduled readings.

5.9. Device status

During its operation, the meter performs tests of individual functions, and in case of an error it creates the "Self-Test Error" event.

The detected errors are represented with FF flag on the LCD display. A corresponding error bit in the FF register is set and an error event is recorded in event log. The FF register is 32 bits long. It is organized in 4 groups of errors:

- Time base errors
- Access data errors
- Checksum errors
- Other errors

LIST OF ERROR STATUSES	hex
TIME BATTERY DISCHARGED	0x01000000
TIME INVALID-TIME	0x02000000
ACCESS RAM	0x00010000
ACCESS FRAM	0x00020000
ACCESS MEASURE	0x00040000
CHECKSUM ROM	0x00000100
CHECKSUM BACK UP DATA	0x00000200
CHECKSUM PARAMETERS	0x00000400
CHECKSUM RAM	0x00002000

LIST OF EVENTS IN EVENT LOG	hex
FATAL ERROR	0x0001
BILLING RESET	0x0010
DEVICE CLOCK CHANGED	0x0020
POWER RETURNED	0x0040
POWER FAILURE	0x0080
EVENT LOG CLEARED	0x2000
LOAD PROFILE CLEARED	0x4000
L1 POWER FAILURE	0x8001
L2 POWER FAILURE	0x8002
L3 POWER FAILURE	0x8003
L1 POWER RETURNED	0x8004
L2 POWER RETURNED	0x8005
L3 POWER RETURNED	0x8006
METER COVER OPENED	0x8010
TERMINAL COVER OPENED	0x8011
NO CONNECTION TIMEOUT (only DLC meters)	0x8012
PREPAY TOKEN ENTER SUCCESS	0x8013
PREPAY TOKEN ENTER FAILED	0x8014
PREPAY CREDIT EXPIRED	0x8015
PREPAY EM CREDIT EXPIRED	0x8016
PREPAY EM CREDIT ACTIVATED	0x8017

5.10. Tariff structure configuration of E-meter

Setting of tariff structures with different combinations of tiers and timeslots including the consumption threshold in the meter (Activity calendar, special days table, register activation).

5.11. Remote customer connection/disconnection

A plug-in switching device (ZO3...) is used for remote disconnection and reconnection of electric network to individual customers.

The meter controls the switching device via control output or via M-Bus.

Control can be performed locally (from the meter) or from a remote control centre using the meter AMR communication.

5.12. Load-profile reading of E-meter

Collection of information saved in profiles of individual customers and/or a larger number of customers.

COSEM Objects
Clock. Profile Status,
M-Bus Ch1 Result 0 – External Meter 1 Consumption,
M-Bus Ch2 Result 0 – External Meter 2 Consumption,
M-Bus Ch3 Result 0 – External Meter 3 Consumption,
M-Bus Ch4 Result 0 – External Meter 4 Consumption,
Load Profile Period 1,
Load Profile Period 2.

Load-profile period 1 is used for hourly values of consumption and Load-profile period 2 is used for daily values of consumption.

5.13. Load-profile reading of G-meter

Collection of information saved in profiles of individual customers and/or a larger number of customers.

Load-profile period 1 is used for hourly values of consumption and Load-profile period 2 is used for daily values of consumption.

5.14. Load-profile configuration of E-meter

Remote configuration of information saved in profiles of individual customers and/or a larger number of customers.

Load-profile configuration enables setting of capture period and capture objects of Load-profile period 1 and Load-profile period 2.

5.15. Load-profile configuration of G-meter

Remote configuration of information saved in profiles of individual customers and/or a larger number of customers.

Load-profile configuration enables setting of capture period and capture objects of Load-profile period 1 and Load-profile period 2.

5.16. Power quality

The meter records events and duration of the power quality parameters.

(L1, L2, L3) - Level 1, $U > +10\%$
(L1, L2, L3) - Level 2, $+5\% < U < +10\%$
(L1, L2, L3) - Level 3, $0\% < U < +5\%$
(L1, L2, L3) - Level 4, $-5\% < U < 0\%$
(L1, L2, L3) - Level 5, $-10\% < U < -5\%$
(L1, L2, L3) - Level 6, $-15\% < U < -10\%$
(L1, L2, L3) - Level 7, $U < -15\%$

TERMINOLOGY	U	TIME
Voltage Dip	$1\% < U < 90\%$	10 ms – 1 Min
Voltage disconnection	$1\% < U < 90\%$	> 1 Min
Temporary Over Voltage	$> 110\%$	10 ms – 1 Min
Over Voltage	$> 110\%$	> 1 Min

5.17. Power failure registration

Power failure registration is collection of power failure duration information of individual customers and/or a larger number of customers.

COSEM Objects
Power Failure Counter
Phase L1 Failure Counter
Phase L2 Failure Counter
Phase L3 Failure Counter
Long Power Failure Counter
Phase L1 Long Failure Counter
Phase L2 Long Failure Counter
Phase L3 Long Failure Counter
Long Power Failures in any Phase Counter
Power Failure Time
Phase L1 Failure Time
Phase L2 Failure Time
Phase L3 Failure Time
Long Power Failures in any Phase Time
Power Failure Duration
Phase L1 Failure Duration
Phase L2 Failure Duration
Phase L3 Failure Duration
Long Power Failures in any Phase Duration
Long Power Interruption Log

TERMINOLOGY	U	TIME
Short power failure	<1%	10 mSec – 5 Sec
Long power failure	<1%	> 5 Sec

The meter has implemented four (4) groups of objects to count power failures, measure their durations and a special event log to log the last 10 long power failures. There is possibility to process four types of power failures:

- Power failure on phase L1
- Power failure on phase L2
- Power failure on phase L3
- Power failure on ALL phases
- Power failure on ANY phase

When power failure occurs in one phase, the meter updates “Power failure logging” registers related to that phase and registers named “ANY”. The counters for the total number of power failures corresponding to that phase and registers “ANY” phase are incremented. Time of power failure occurrence is stored to corresponding phase and “ANY” phase register. When power is returned, the meter calculates duration of the last power failure. If calculated duration is less than 3 minutes, the power failure is declared as brief power failure. Power failures longer than 3 minutes are counted as long power failures and occurrence of such power failure is recorded in “Power Failure Log”. The log capacity is 10 records.

“Power Failure Log” is instance of the COSEM class “Profile generic”. New record is inserted to the log only in cases when duration of power failure on ANY phase is longer than 3 minutes. Objects captured to the buffer are:

- Time stamp of the record (end of power failure),
- Time of power failure in any phase,
- Duration of failure in any phase.

5.18. Alarms

The meter detects internal alarms and sends them to the central system. The alarm parameters are predefined. The priority levels of alarms are adjustable. If an alarming situation has occurred, the alarm is handled by the system and reset if necessary.

COSEM Objects
Auto dial
Alarm ON status
Alarm ON operations
Alarm OFF status
Alarm OFF operations
Power Failure Alarm Filtering Limit
Power Failure Alarm ON Delay
Power Failure Alarm OFF Delay

List of alarms:

ALARM	BIT
ALARM INPUT 1	0
ALARM INPUT 2	3
TERMINAL COVER OPEN	6
METER COVER OPEN	7
PHASE L1 MISSING	8
PHASE L2 MISSING	9
PHASE L3 MISSING	10
ASYMMETRICAL VOLTAGE	14
SYSTEM ALARM POWER FAIL	15
NEUTRAL 0 CURRENT AT ASYMM. LOAD	16
UNUSED UNEXPECTED CONSUMPTION	17
SYSTEM ALARM INSTALLATION	24
FATAL FAULT	31

5.19. Commission E-meter

Commissioning the meter is preparing the meter to be handled by the system: the meter becomes operational. During installation in the field, the meter is updated with the physical installation data like customer ID, postal code or similar. During installation, the current configuration as well as other relevant parameters shall be saved.

During installation, the meter is commissioned via the optical port by a hand-held device by an installer. The installer enters and reads a list of relevant information in the meter by means of an installer security key:

- Time synchronization
- Security key
- Tariff structure ID
- ZIP code
- Meter ID
- Reset alarms
- Disable installation keys

After commissioning, the meter disables the installation key and blocks the optical port for communication except for specific readings due to data recovery, testing and calibration.

COSEM Objects accessed with commissioning:

Logical Name	Class ID	Description
0-0:96.1.8.255	1	Device ID 9 – Meter ID
0-0:96.1.1.255	1	Device ID 2 – ZIP code
1-0:1.8.0.255	3	A+, Time Integral 1, Total, Current Billing Period
1-0:1.8.1.255	3	A+, Time Integral 1, Tariff 1, Current Billing Period
1-0:1.8.2.255	3	A+, Time Integral 1, Tariff 2, Current Billing Period
1-0:1.8.3.255	3	A+, Time Integral 1, Tariff 3, Current Billing Period

1-0:1.8.4.255	3	A+, Time Integral 1, Tariff 4, Current Billing Period
1-0:2.8.0.255	3	A-, Time Integral 1, Total, Current Billing Period
1-0:2.8.1.255	3	A-, Time Integral 1, Tariff 1, Current Billing Period
1-0:2.8.2.255	3	A-, Time Integral 1, Tariff 2, Current Billing Period
1-0:2.8.3.255	3	A-, Time Integral 1, Tariff 3, Current Billing Period
1-0:2.8.4.255	3	A-, Time Integral 1, Tariff 4, Current Billing Period
0-1:128.50.21.255	1	M-Bus Ch1 Customer ID – External Meter 1 ID
0-1:128.50.0.255	4	M-Bus Ch1 Result 0 – External Meter 1 Consumption
0-0:1.0.0.255	8	Clock
0-0:13.0.0.255	20	Activity Calendar
0-0:11.0.0.255	11	Special Days Table
1-0:96.242.0	1	Alarm ON status
1-0:96.243.0	1	Alarm OFF status
1-0:96.244.0	1	Alarm status
0-0:10.1.252.255	9	Security Script Table

5.20. Security

A security model includes authentication and encryption of data on different levels. Authentication and encryption keys are delivered from concentrators to meters. Meters are installed and commissioned to get the default keys which are changed remotely to operational keys.

COSEM Objects
Security Policy
Authentication Key 1
Authentication Key 2
Authentication Key 3
Authentication Key 4
Encryption Key 1
Default Encryption Key 1
Security Script Table

6. Data protection

Special attention is paid to a system of meter data protection in order to prevent meter tampering. Access to the billing data registers in order to change their values is not possible. Entering the RTC correction constant, meter configuration and auxiliary terminals can be performed only after entering an eight digit password and pressing the Param push-button that is under the meter cover.

7. Meter connection procedure

1. The meter should be fixed with screws at the place of measurement.

2. The meter should be connected according to the meter connection diagram that is attached to the meter terminal cover. Torque of the screws tightening in the current terminals is 2.5 Nm.
3. The meter operation should be checked:
 - The LED is turned on (load current is lower than the meter starting current)
 - The LED is blinking with frequency proportional to the engaged electric power (the meter measures and records energy)
 - The LED is turned off (the meter is not energized). In this case it should be checked if:
 - a. current conductors are connected to the meter (if not, they should be connected)
 - b. the potential links are in their bottom position (if not, the potential link slides should be pushed to their bottom position)
 - c. If both upper conditions are fulfilled, it means that there is no voltage in the mains.
4. Check the **L1 L2 L3** indicator (MT37y) on the LCD if the meter conductors are connected regularly:
 - The indicators **L1**, **L2** and **L3** are displayed – all three phase voltages are present
 - Some of the indicators **L1**, **L2** and **L3** are not displayed – voltage in the phase(s) is (are) not present. In this case, it should be checked if the current conductors of this (these) phase(s) is (are) connected to the meter. If they are connected, a cause of the missing phase voltage should be found and removed.
 - The indicators **L1**, **L2** and **L3** are blinking – Reversed phase sequence. The indicator is blinking only if the rotating magnetic field rotates counter-clockwise. In this case, the phase sequence of the connected current wires should be checked or a place of reversed phase sequence should be found and its cause should be removed.

NOTE: The reversed phase sequence does not influence in the accuracy of energy measurement!

- Check date and time set in the internal RTC and, if needed, set the correct values
- If the meter is equipped with GSM/GPRS communication interface see item 7.1.
- Make billing reset of the meter
- Seal the meter (terminal cover and the lid of the orange push-button).

7.1. Connection procedure of GSM/GPRS communication interface

Checking of the presence of a SIM card

1. Remove a terminal cover.
2. Check if a SIM card is inserted as shown in a figure below



Fig. 36: SIM card bed

3. If a SIM card is not inserted, insert it into the shown place

Check the GSM/GPRS signal strength on LCD:

- a. **The flag is permanently lit;** good covering with a GSM/GPRS signal.
- b. **The flag is blinking;** bad covering with the GSM/GPRS signal. It is recommended to find a better location for meter installation.
- c. **The flag is not lit;** it is recommended to find a better location for installation. If the flag is not lit even at a new place, an external antenna is required.

Note: limits are adjustable

8. Accessory for meters managing

For meters managing the following accessories are available:

- **For maintaining meter programming and data down-loading:**
 - MeterView (Iskraemeco software)
 - Optical probe
 - Personal computer: PC, desktop, laptop.

The accessory is intended for the person who maintains and programs meters in a repair shop and in the field.

- **For meter reading and programming in the field:**
 - MeterRead (Iskraemeco software) for all types of hand-held computers (Palmtop PC), utilizing the Windows CE operation system
 - Optical probe
- **For remote meter reading and programming:**
 - SEP2W (Iskraemeco software, with modules for remote meter reading, data base management and a module for data presentation and printing)
 - Central station – a server with corresponding software and hardware

9. Meter maintaining

No maintenance is required during the meters life. The implemented metering technique, built-in

components and manufacturing procedures ensure high long-term stability of meters, so that there is no need for their recalibration during their life.

10. Anti-fraud protection

The meter cover and the meter terminal cover are sealed by means of sealing screws and conventional wire seals. Unless the seals are broken, the access into the meter enclosure is not possible.

On customer's demand the meter can be equipped with special internal switches for the detection of any lifting of the meter cover or meter terminal cover.

10.1. Position of the seals

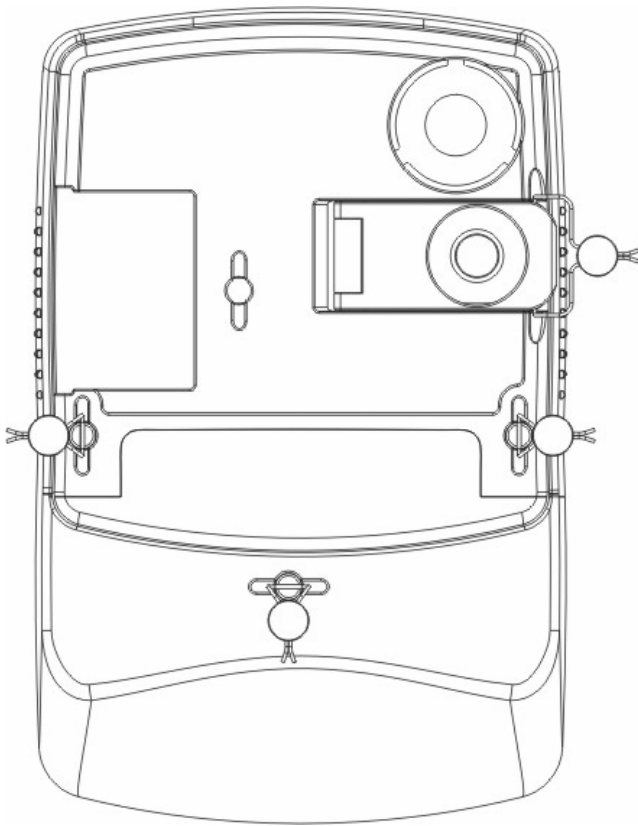

Fig. 37: ME37y meter position of the seals

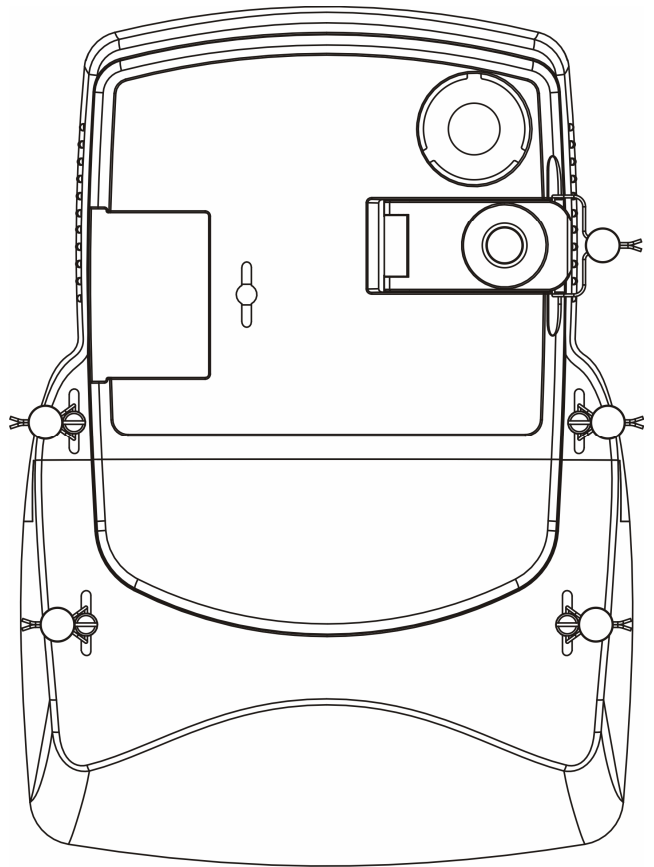

Fig. 38: MT372 meter position of the seals

10.2. Wire seals



Fig. 39: Different types of protective wire seals

11. Front plate

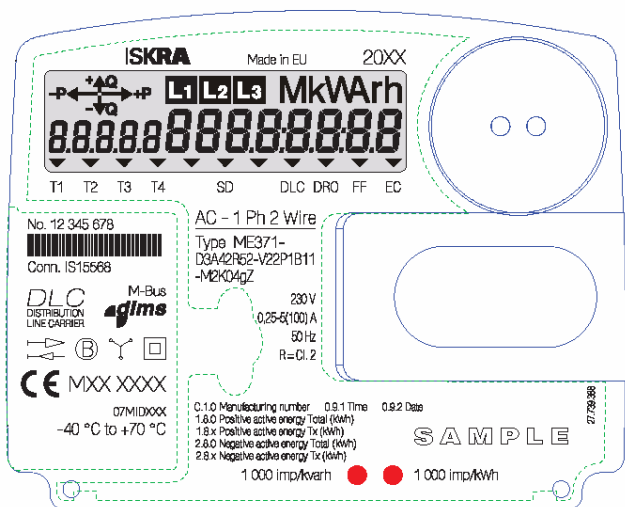

Fig. 40: ME371-D3 meter front plate

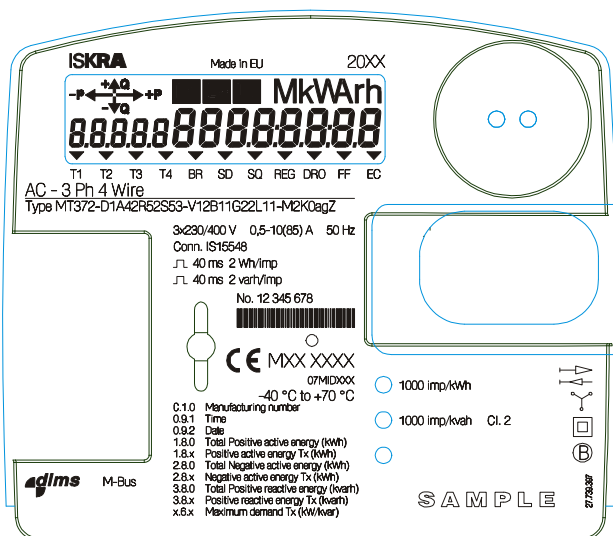

Fig. 41: MT372-D1 meter front plate

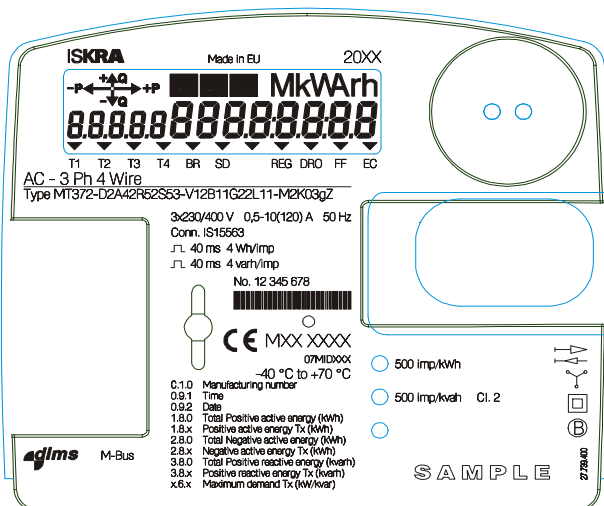

Fig. 42: MT372-D2 meter front plate

12. Meter connection

The meter connection diagram is stuck on the internal side of the terminal cover.

12.1. Meter connection of ME37y meters

Meters can be connected in single-phase two-wire networks.

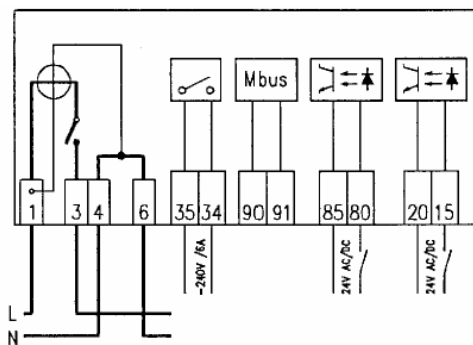

Fig. 43: Connection diagram of ME371 meter

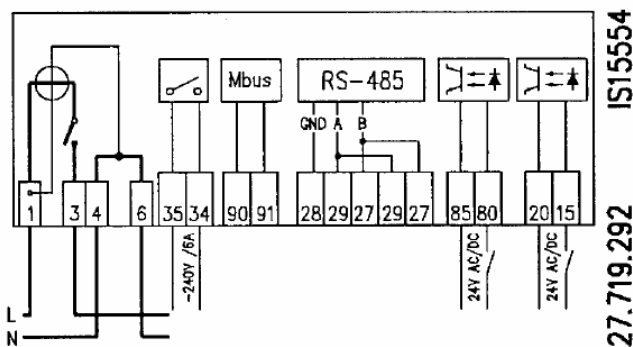

Fig. 44: Connection diagram of ME372 meter with RS 485 communication interface

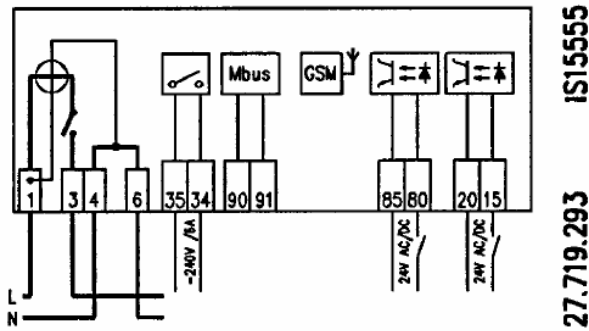

Fig. 45: Connection diagram of ME372 meter with GSM/GPRS modem

Communication interface – M-Bus

Hardware type	Function	Terminal
Communication interface	Common	90
Communication interface	Mini master	91

Communication interface – RS485

Hardware type	Function	Terminal
RS485 – GND	G	28
RS485 – A	B	27
RS485 – B	A	29
RS485 – A	B	27
RS485 – B	A	29

Inputs

Hardware type	Function	Terminal
	Common	20
Low voltage (up to 24 V, 27 mA)	Alarm input	15
	Common	85
Low voltage (up to 24 V, 27 mA)	Alarm input	80

Outputs

Hardware type	Function	Terminal
	Common	35
High voltage (250 V, 6 A)	Load control	34

12.2. Meter connection of MT37y meters

Meters can be connected in three-phase four- or three-wire networks, as well as in a single-phase two-wire network. Irrespective of the network type where meters are installed, they keep their declared metering properties.

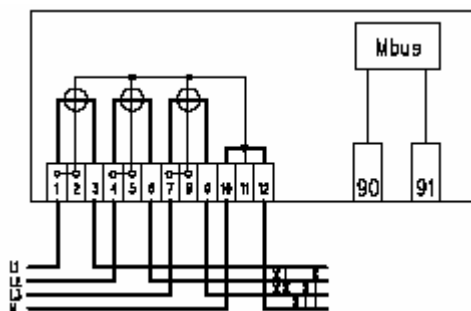

Fig. 46: Connection diagram of MT371 meter with M-Bus communication interface

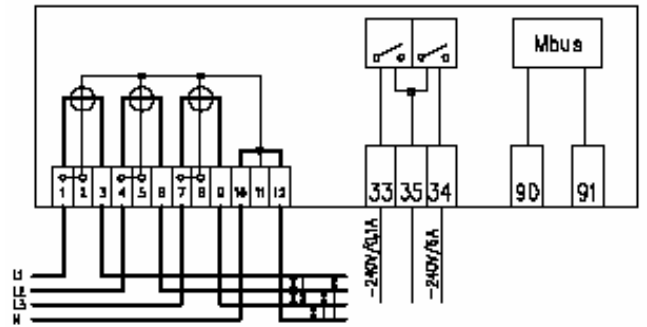

Fig. 47: Connection diagram of MT371 meter with outputs and M-Bus communication interface

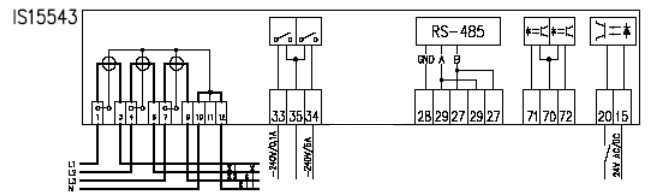

Fig. 48: Connection diagram of MT372 meter with RS 485 communication interface

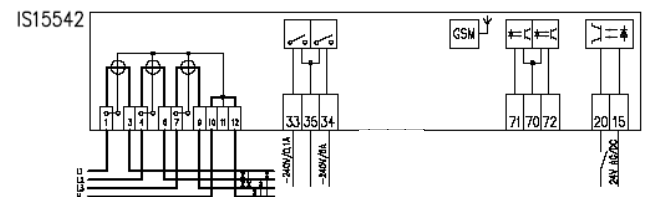

Fig. 49: Connection diagram of MT372 meter with GSM/GPRS modem

Communication interface – RS485

Hardware type	Function	Terminal
RS485 – GND	GND	28
RS485 – B	B	27
RS485 – A	A	29
RS485 – B	B	27
RS485 – A	A	29

Low voltage transistor output

Hardware type	Function	Terminal
Low voltage (up to 24 V, 27 mA)	Transistor	71
	Common	70
Low voltage (up to 24 V, 27 mA)	Transistor	72

Inputs

Hardware type	Function	Terminal
	Common	20
Low voltage (up to 24 V, 27 mA)	Alarm input	15
	Common	85
Low voltage (up to 24 V, 27 mA)	Alarm input	80

Outputs

Hardware type	Function	Terminal
High voltage (250 V, 100 mA)	Optomos	33
	Common	35
High voltage (250 V, 6 A)	Load control	34

Communication interface – M-Bus

Hardware type	Function	Terminal
Communication interface	Common	90
Communication interface	Mini master	91

13. Technical data
GENERAL METER MEASURING CHARACTERISTICS

Accuracy class	- Active: 2 or 1 (IEC 62052-11) Active: A or B (MID) - Reactive: 3 or 2 (IEC 62052-11) - Apparent energy measurement, 3.0%
Nominal current	5 A
Max. current – direct connection	85 A
Max. current – direct connection	120 A
I_{max} – transformer connection	6 A
Thermal current	$1.2 I_{max}$ – direct connection
Starting current	$<0.005 I_b$ at $\cos \varphi = 1$, for class 2 $<0.004 I_b$ at $\cos \varphi = 1$, for class 1
Short-circuit current	$30 I_{max}$
Nominal voltage	3x230/400 V, 3x400 V other voltages on request
Voltage range	$0.8 U_n \dots 1.15 U_n$
Nominal frequency	50 Hz or 60 Hz
Meter constant (impulse LED), active and reactive measurement	1000 imp/kWh at $I_{max} = 85$ A 500 imp/kWh at $I_{max} = 120$ A 10000 imp/kWh at $I_{max} = 6$ A
Temperature range of operation	$-25^\circ\text{C} \dots +60^\circ\text{C}$
Extended temperature range	$-40^\circ\text{C} \dots +70^\circ\text{C}$
Storing temperature	$-40^\circ\text{C} \dots +80^\circ\text{C}$
Voltage circuit self-consumption	< 2 W / 10 VA
Current circuit self-consumption	< 0.16 VA irrespective of nominal current I_n
INTERNAL CLOCK	
Accuracy (@25°C)	≤ 5 ppm or $\leq \pm 3$ min / year
Reserve power supply	> 150 hours, super-capacitor
Clock signal	Quartz crystal 32 kHz
OPTICAL COMMUNICATION INTERFACE	
Interface	IEC62056-21 Mode E,
Protocol	IEC62056-46, Registers marking in compliance with OBIS (IEC62056-61)
Transmission rate	19200 bit/sec

DLC modem	
Protocol	DLMS (IEC 62056-46),
Data identification code	OBIS (IEC 62056-61)
Data transmission rate via low-voltage network	max. 1.200 bit/sec
Data transmission rate between the microprocessor and the DLC modem	4,800 bit/sec
RS485 communication interface	
Protocol	IEC62056-46, marking of registers in compliance with OBIS (IEC62056-61)
Data transmission rate	19200 bit/sec
GSM/GPRS communication interface	
Protocol	IEC62056-46,
Data transmission rate	GSM: 9600 bit/sec GPRS: 28000 bit/sec Actual rate depends on network configuration!
LOAD- PROFILE	
No. of load-profiles	2
OUTPUTS	
Control output - high voltage output	Hardware type: Bistable relay Output type; Load control Switching voltage: 250 V Switching current: 6 A
Control output - high voltage output	Hardware type: Optomos Output type; Service control Switching voltage: 250 V Switching current: 100 mA
Low voltage output	Hardware type: Transistor Output type; switching device control or impulse output Switching voltage: 24 V Switching current: 27 mA
INPUTS	
Low voltage input	HW type: Passive transistor input Input type: Alarm input (1 and 2) Switching voltage: 3 – 24 V AC/DC
SWITCHING DEVICE	
Switching device	Input type: 3(4) x Bistable relay Switching voltage: 3 x 440 V Switching current: 3(4) x 100 A
METER RESISTANCE TO ELECTROMAGNETIC DISTURBANCES	
Insulation strength	4 kV, 50 Hz, 1 min
Electrostatic discharges	15 kV (IEC 1000-4-2)
Electromagnetic field	10 V/m (IEC 1000-4-3)
Burst test – high-freq. disturbances	4 kV (IEC 1000-4-4)
Shock voltage	12 kV, 1,2/50 μ s (IEC 62053-21) – to meter main circuit
DIMENSIONS	
ME37y meter: Mass	200 x 132 x 82 mm approx. 800 g
MT371 meter: Mass	250 x 178 x 55 mm approx. 1000 g

MT371 meter with switching device: Mass	310 x 178 x 108 mm approx. 1650 g
ME372 meter: Mass	250 x 178 x 86 mm approx. 1300 g
MT372 meter with switching device: Mass	310 x 178 x 108 mm approx. 1950 g

Table – Technical data

Terminal data:

ME37y-D1

No.	Function	Nominal voltage	Max. current	Diam mm	Note	Wire mm ²	Screw type	Moment Nm
1	IL1 – in	3x230/400 V	85 A	8.5	Current	25	Pozidriv (2)	2.5
3	IL1 – out	3x230/400 V	85 A	8.5	Current	25	Pozidriv (2)	2.5
4	IL2 – in	3x230/400 V	85 A	8.5	Current	25	Pozidriv (2)	2.5
6	IL2 – out	3x230/400 V	85 A	8.5	Current	25	Pozidriv (2)	2.5
15	Alarm input			2.5	Common	1.5	Regular (0.6x3.5)	0.6
20		3-24 V AC/DC		2.5	Optomos	1.5	Regular (0.6x3.5)	0.6
27	RS485			2.5	B	1.5	Regular (0.6x3.5)	0.6
28				2.5	GND	1.5	Regular (0.6x3.5)	0.6
29				2.5	A	1.5	Regular (0.6x3.5)	0.6
35	Load control			2.5	Common	1.5	Pozidriv (1)	0.6
34		250 V	6 A	2.5	Relay	1.5	Pozidriv (1)	0.6
90	Mbus			2.5		1.5	Pozidriv (1)	0.6
91				2.5		1.5	Pozidriv (1)	0.6

MT37y-D1

No.	Function	Nominal Voltage	Max. Current	Diam mm	Note	Wire mm ²	Screw type	Moment Nm
1	IL1 – in	3x230/400 V	85 A	8.5	Current	25	Pozidriv (2)	2.5
2	UL1 – aux	3x230/400 V		3.0	Voltage	1.5	Pozidriv (1)	0.6
3	IL1 – out	3x230/400 V	85 A	8.5	Current	25	Pozidriv (2)	2.5
4	IL2 – in	3x230/400 V	85 A	8.5	Current	25	Pozidriv (2)	2.5
5	UL2 – aux	3x230/400 V		3.0	Voltage	1.5	Pozidriv (1)	0.6
6	IL2 – out	3x230/400 V	85 A	8.5	Current	25	Pozidriv (2)	2.5
7	IL3 – in	3x230/400 V	85 A	8.5	Current	25	Pozidriv (2)	2.5
8	UL3 – aux	3x230/400 V		3.0	Voltage	1.5	Pozidriv (1)	0.6
9	IL1 – out	3x230/400 V	85 A	8.5	Current	25	Pozidriv (2)	2.5
10	N – in	3x230/400 V		8.5	Neutral	25	Pozidriv (2)	2.5
11	N – aux	3x230/400 V		3.0	Neutral	1.5	Pozidriv (1)	0.6
12	N - out	3x230/400 V		8.5	Neutral	25	Pozidriv (2)	2.5
71	Output for switching device			2.5	Connect	1.5	Regular (0.6x3.5)	0.6
70				2.5	Common	1.5	Regular (0.6x3.5)	0.6
72				2.5	Disconnect	1.5	Regular (0.6x3.5)	0.6
15	Alarm input			2.5	Common	1.5	Regular (0.6x3.5)	0.6
20		3-24 V AC/DC		2.5	Optomos	1.5	Regular (0.6x3.5)	0.6
33	Load control	250 V	100 mA	2.5	Optomos	1.5	Pozidriv (1)	0.6
35				2.5	Common	1.5	Pozidriv (1)	0.6
34		250 V	6 A	2.5	Relay	1.5	Pozidriv (1)	0.6
27	RS485			2.5	B	1.5	Regular (0.6x3.5)	0.6
28				2.5	GND	1.5	Regular (0.6x3.5)	0.6
29				2.5	A	1.5	Regular (0.6x3.5)	0.6

MT37y-D2

No.	Function	Nominal voltage	Max. current	Diam mm	Note	Wire mm ²	Screw type	Moment Nm
1	IL1 – in	3x230/400 V	120 A	9.5	Current	35	Pozidriv (2)	2.5
2	UL1 – aux	3x230/400 V		3.0	Voltage	1.5	Pozidriv (1)	0.6
3	IL1 – out	3x230/400 V	120 A	9.5	Current	35	Pozidriv (2)	2.5
4	IL2 – in	3x230/400 V	120 A	9.5	Current	35	Pozidriv (2)	2.5
5	UL2 – aux	3x230/400 V		3.0	Voltage	1.5	Pozidriv (1)	0.6
6	IL2 – out	3x230/400 V	120 A	9.5	Current	35	Pozidriv (2)	2.5
7	IL3 – in	3x230/400 V	120 A	9.5	Current	35	Pozidriv (2)	2.5
8	UL3 – aux	3x230/400 V		3.0	Voltage	1.5	Pozidriv (1)	0.6
9	IL3 – out	3x230/400 V	120 A	9.5	Current	35	Pozidriv (2)	2.5
10	N – in	3x230/400 V		9.5	Neutral	35	Pozidriv (2)	2.5
11	N – aux	3x230/400 V		3.0	Neutral	1.5	Pozidriv (1)	0.6
12	N - out	3x230/400 V		9.5	Neutral	35	Pozidriv (2)	2.5
71	Output for switching device			2.5	Connect	1.5	Regular (0.6x3.5)	0.6
70				2.5	Common	1.5	Regular (0.6x3.5)	0.6
72				2.5	Disconnect	1.5	Regular (0.6x3.5)	0.6
15	Alarm Input	3-24 V AC/DC		2.5	Optomos	1.5	Regular (0.6x3.5)	0.6
20				2.5	Common	1.5	Regular (0.6x3.5)	0.6
33	Load control	250 V	100 mA	2.5	Optomos	1.5	Pozidriv (1)	0.6
35				2.5	Common	1.5	Pozidriv (1)	0.6
34				250 V	6 A	2.5	Relay	1.5

MT37y-T1

No.	Function	Nominal voltage	Max. current	Diam mm	Note	Wire mm ²	Screw type	Moment Nm
1	IL1 – in		5(6) A	5.0	Current	6	Pozidriv (1)	1.0
2	UL1	3x230/400 V		5.0	Voltage	6	Pozidriv (1)	1.0
2	UL1 – aux	3x230/400 V		3.2	Voltage	4	Regular (0.6x3.5)	0.6
3	IL1 – out		5(6) A	5.0	Current	6	Pozidriv (1)	1.0
4	IL2 – in		5(6) A	5.0	Current	6	Pozidriv (1)	1.0
5	UL2	3x230/400 V		5.0	Voltage	6	Pozidriv (1)	1.0
5	UL2 – aux	3x230/400 V		3.2	Voltage	4	Regular (0.6x3.5)	0.6
6	IL2 – out		5(6) A	5.0	Current	6	Pozidriv (1)	1.0
7	IL3 – in		5(6) A	5.0	Current	6	Pozidriv (1)	1.0
8	UL3	3x230/400 V		5.0	Voltage	6	Pozidriv (1)	1.0
8	UL3 – aux	3x230/400 V		3.2	Voltage	4	Regular (0.6x3.5)	0.6
9	IL3 – out		5(6) A	5.0	Current	6	Pozidriv (1)	1.0
11	N	3x230/400 V		5.0	Neutral	6	Pozidriv (1)	1.0
12	N - aux	3x230/400 V		3.2	Neutral	4	Regular (0.6x3.5)	1.0
71	Impulse output			2.5	SO output	1.5	Regular (0.6x3.5)	0.6
70				2.5	Common	1.5	Regular (0.6x3.5)	0.6
72				2.5	SO output	1.5	Regular (0.6x3.5)	0.6
15	Alarm input	3-24 V AC/DC		2.5	Optomos	1.5	Regular (0.6x3.5)	0.6
20				2.5	Common	1.5	Regular (0.6x3.5)	0.6
33	Load control	250 V	100 mA	2.5	Optomos	1.5	Pozidriv (1)	0.6
35				2.5	Common	1.5	Pozidriv (1)	0.6
34				250 V	6 A	2.5	Relay	1.5

Owing to periodically improvements of our products the supplied products can differ in some details from data stated in this technical description.

Iskraemeco d.d., Energy Measurement and Management
4000 Kranj, Savska loka 4, Slovenia
Telephone (+386 4) 206 40 00, Fax: (+386 4) 206 43 76
<http://www.iskraemeco.si>, E-mail: info@iskraemeco.si

Published: Iskraemeco, Marketing, Data subjected to alteration without notice.

Mx37y_Technical_Description_ENG_v2.00.doc